

# ECB16S/18S

**CHARGE FOR ONE HOUR. RUN FOR SEVEN\***

3,500 lbs - 4,000 lbs | 80V AC Motor | Zero Battery Maintenance | 10-year Battery Warranty



## WORK SMARTER

With rapid, restriction-free charging, BYD forklifts operate across multiple shifts without the need to change or replace batteries. Built using iron-phosphate technology, each forklift includes a state-of-the-art Battery Management System and the longest battery warranty in the industry. With BYD, peace of mind is assured.

\*Runtimes and charging rates vary depending on model, charger and application



# ECB16S/18S Specifications

				ECB16S	ECB18S
	Load capacity: rated load to 118" @ 24" LC		lb	3500	4000
	Operating voltage		v	80 volts	80 volts
	Drive Motors			Single	Single
Dimensions	Length to face of forks	l2	in	83.7	83.7
	Minimum turning radius	Wa	in	73.2	73.2
	Load distance, center wheel to face of forks	x	in	16.5	16.5
	Basic right-angle stack (add load and clearance)		in	89.8	89.8
	Overall width	b1	in	41.3	41.3
	Seat height	h7	in	39.6	39.6
	Overhead guard height	h6	in	80.7	80.7
	Carriage width	b3	in	40.1	40.1
	Carriage ITA Type			II	II
	Tilt range (forward/backward)		deg	5/8	5/8
	Ground clearance with load, below mast	m1	in	3.3	3.3
Performance	Travel speed (loaded/unloaded)		MPH	10 / 10	10 / 10
	Lift speed (loaded/unloaded)		FPM	83 / 90	83 / 90
	Lowering speed (loaded/unloaded)		FPM	102 / 94	102 / 94
	Max gradeability (loaded/unloaded)		%	20 / 20	20 / 20
Power System	Drive motor rating (S2=60 min)		KW	9	9
	Lift motor rating (S3=15% ED)		KW	16	16
	Battery capacity		KWh	21.6	21.6
	Charging time			1.3h	1.3h
	Battery weight		lb	1433	1433
	Type of drive control			AC	AC
Weight	Service weight including battery		lb	7348	7678
	Axle load, fully loaded (front/rear)		lb	9274 / 1618	10039 / 1625
	Axle load, unloaded (front/rear)		lb	3428 / 3935	3461 / 4233
Tires	Wheel size, front wheel or driving wheel		Spec	6.00-9	6.00-9
	Wheel size, rear wheel or supporting wheel		Spec	16x6-8	16x6-8
	Track width front	b10	in	35.04	35.04
	Track width rear	b11	in	34.25	34.25

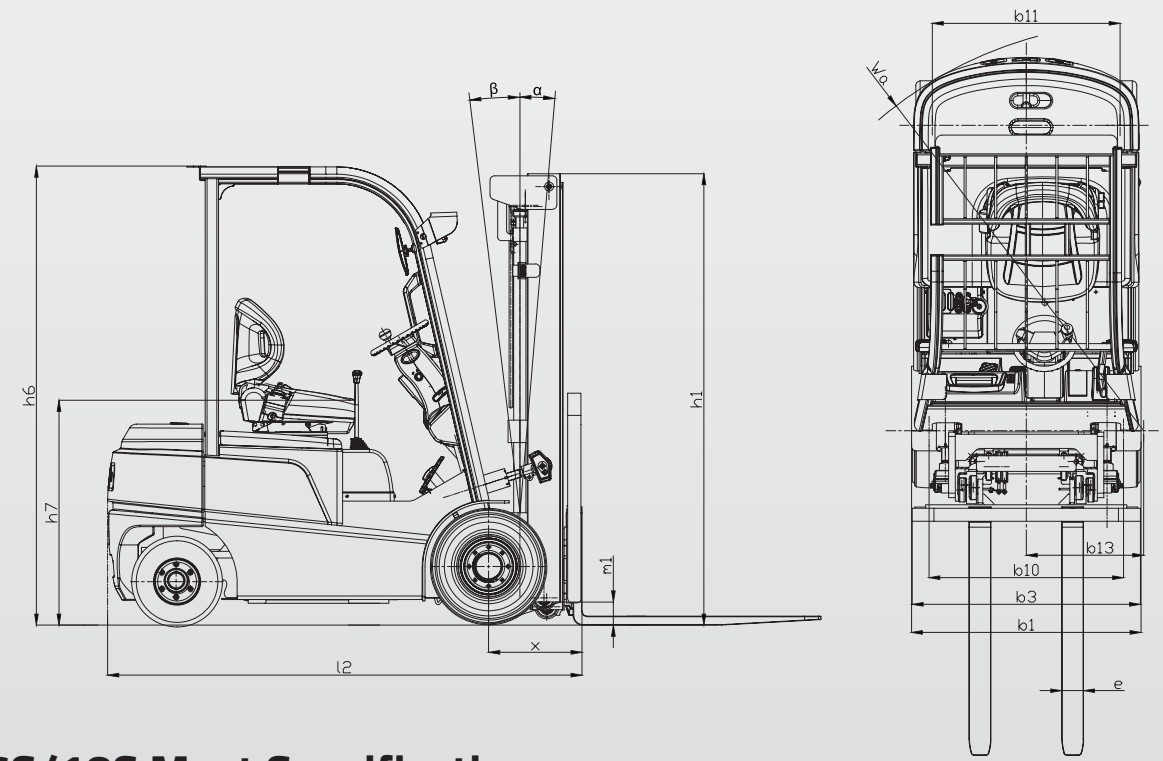

## ECB16S/18S Mast Specifications

Mast Specifications (in)	Fork Height	Free Lift	Collapsed Height	Extended Height	Fwd Tilt	Back Tilt	Capacity 24" LC	
							ECB16S	ECB18S
2-Stage Standard Mast	118	5	80	157	5°	8°	3528	4000
	130	5	85	169	5°	8°	3528	3859
	138	5	89	177	5°	8°	3473	3786
	157	5	101	196	5°	8°	3296	3601
	177	5	111	216	5°	5°	3041	3330
2-Stage FFL Mast	197	5	123	236	5°	5°	2889	3169
	118	41	80	157	5°	8°	3528	3969
	130	47	85	169	5°	8°	3528	3859
	138	51	89	177	5°	8°	3473	3786
	157	62	101	196	5°	8°	3296	3601
3-stage FFL Mast	157	53	77	198	5°	5°	3296	3601
	177	59	83	218	5°	5°	3041	3330
	189	63	87	230	5°	5°	2946	3233
	197	65	89	238	5°	5°	2889	3169
	209	69	93	250	5°	5°	2798	3076
	217	71	95	257	5°	3°	2734	3008
	228	77	100	269	5°	3°	2642	2908
236	80	105	277	5°	3°	2573	2838	
256	88	112	297	5°	3°	2249	2178	



# ECB16S/18S FEATURES

## STANDARD EQUIPMENT

Iron Phosphate Battery Technology  
Battery 80V ■ 21.6 kWh ■ 270Ah  
Charger 80V ■ 200A  
80V AC Drive Motor  
Regenerative Braking  
LED Lights (Front ■ Rear ■ Strobe)  
LCD Display  
4-Way Hydraulic Valve  
Rear Grab Handle with Horn  
Rearview Mirrors  
Ramp Hold Assist

## STANDARD SAFETY FEATURES

Cornering Speed Reduction  
Operator Presence Sensor (OPS)  
Orange Seatbelt with Interlock

## OPTIONAL EQUIPMENT

Universal 110V Wall Charger  
Charger 80V ■ 100A  
Grammer® Suspension Seat  
Blue Light  
Rear Working Light  
Full or Partial Cab Enclosure



**BYD Motors LLC**

18910 S Wilmington Ave  
Rancho Dominguez, CA 90220

BYD Forklift production site is certified:  
**ISO 9001 ISO 14004 OHSAS 18001**

 1-800-293-2886

 [byd-forklifts.com](http://byd-forklifts.com)

 [sales@byd-forklifts.com](mailto:sales@byd-forklifts.com)