

# ECB30/35

**CHARGE FOR ONE HOUR. RUN FOR SEVEN\***

6,600 lbs - 7,500 lbs | 80V AC Motor | Zero Battery Maintenance | 10-year Battery Warranty



## WORK SMARTER

With rapid, restriction-free charging, BYD forklifts operate across multiple shifts without the need to change or replace batteries. Built using iron-phosphate technology, each forklift includes a state-of-the-art Battery Management System and the longest battery warranty in the industry. With BYD, peace of mind is assured.

\*Runtimes and charging rates vary depending on model, charger and application



# ECB30/35 Specifications

			ECB30 B/C	ECB30 D/E	ECB35 B/C	ECB35 D/E
	Load capacity: rated load to 118" @ 24" LC	lb	6600	6600	7500	7500
	Operating voltage	v	80 volts	80 volts	80 volts	80 volts
	Drive Motors		Dual	Single	Dual	Single
Dimensions	Length to face of forks	l2	100.8	100.8	100.8	100.8
	Minimum turning radius	Wa	87.0	89.4	87.0	89.4
	Load distance, center wheel to face of forks	x	18.1	19.7	18.1	19.7
	Basic right-angle stack (add load and clearance)		105.1	109.1	105.1	109.1
	Overall width	b1	53.5	53.5	53.5	53.5
	Seat height	h7	44.9	44.9	44.9	44.9
	Overhead guard height	h6	87.2	87.2	87.2	87.2
	Carriage width	b3	43.3	43.3	43.3	43.3
	Carriage ITA Type		III	III	III	III
	Tilt range (forward/backward)	deg	5 / 8	5/8	5/8	5/8
	Ground clearance with load, below mast	m1	4.3	4.3	4.3	4.3
	Performance	Travel speed (loaded/unloaded)	MPH	12 / 12	9 / 9	12 / 12
Lift speed (loaded/unloaded)		FPM	75 / 89	75 / 89	75 / 89	75 / 89
Lowering speed (loaded/unloaded)		FPM	108 / 89	108 / 89	108 / 89	108 / 89
Max gradeability (loaded/unloaded)		%	20 / 20	15 / 20	20 / 20	15 / 20
Power System	Drive motor rating (S2=60 min)	KW	2 x 10	22	2 x 10	22
	Lift motor rating (S3=15% ED)	KW	24	24	24	24
	Battery capacity	KWh	21.6 / 43.2	21.6 / 43.2	21.6 / 43.2	21.6 / 43.2
	Charging time		1.3h / 2.6h	1.3h / 2.6h	1.3h / 2.6h	1.3h / 2.6h
	Battery weight	lb	1367	1367	1367	1367
	Type of drive control		AC	AC	AC	AC
Weight	Service weight including battery	lb	10648	11024	11968	12320
	Axle load, fully loaded (front/rear)	lb	14758 / 2529	15593 / 2046	17027 / 2685	17889 / 2176
	Axle load, unloaded (front/rear)	lb	4460 / 2211	5144 / 5880	5014 / 6981	5697 / 6650
Tires	Wheel size, front wheel or driving wheel	Spec	23x10-12	23x10-12	23x10-12	23x10-12
	Wheel size, rear wheel or supporting wheel	Spec	200/50-10	200/50-10	200/50-10	200/50-10
	Track width front	b10	43.7	44.09	43.70	44.09
	Track width rear	b11	37.6	37.60	37.60	37.60

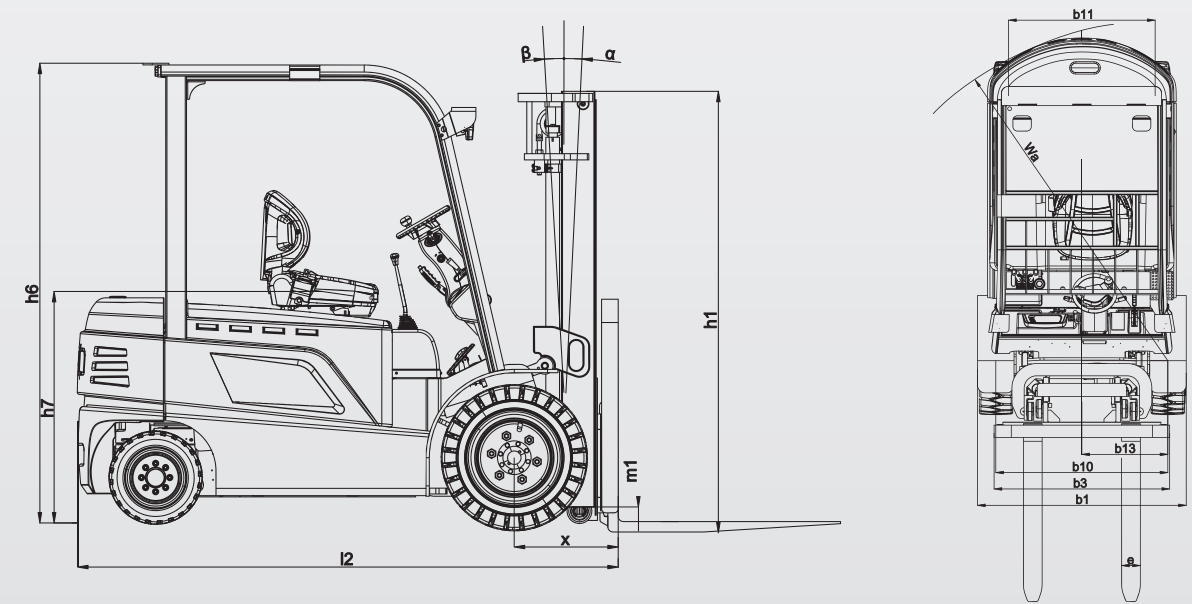

## ECB30/35 Mast Specifications

Mast Specifications (in)	Fork Height	Free Lift	Collapsed Height	Extended Height	Fwd Tilt	Back Tilt	Capacity 24" LC	
							ECB30	ECB35
2-Stage Standard Mast	118	5	83	157	5°	8°	6615	7563
	130	5	89	169	5°	8°	6417	7343
	138	5	93	177	5°	8°	6306	7210
	146	5	97	185	5°	8°	6152	7056
	157	5	103	197	5°	8°	5998	6880
	177	5	114	217	5°	6°	5645	6483
	189	5	120	228	5°	6°	5468	6306
	197	5	128	236	5°	6°	5380	6218
	217	5	136	256	5°	6°	5138	5931
	236	5	146	276	5°	6°	4851	5645
2-Stage FFL Mast	118	45	83	157	5°	8°	6615	7563
	130	51	89	169	5°	8°	6417	7343
	138	55	93	177	5°	8°	6306	7210
	157	65	103	197	5°	8°	5998	6880
	177	45	82	197	5°	6°	5998	6880
3-stage FFL Mast	171	49	87	211	5°	6°	5711	6571
	177	51	89	217	5°	6°	5645	6836
	189	55	93	228	5°	6°	5468	6483
	197	58	95	236	5°	6°	5380	6218
	209	62	99	248	5°	6°	5226	6020
	217	64	102	256	5°	6°	5138	5909
	236	71	108	276	5°	6°	4851	5645
	256	77	115	295	5°	3°	4631	5292



# ECB30/35 FEATURES

## STANDARD EQUIPMENT

Iron Phosphate Battery Technology  
Battery 80V ■ 21.6 kWh ■ 270Ah  
Charger 80V ■ 200A  
80V AC Drive Motor(s)  
Regenerative Braking  
LED Lights (Front ■ Rear ■ Strobe)  
LCD Display  
4-Way Hydraulic Valve  
Rear Grab Handle with Horn  
Rearview Mirrors  
Ramp Hold Assist

## STANDARD SAFETY FEATURES

Cornering Speed Reduction  
Operator Presence Sensor (OPS)  
Orange Seatbelt with Interlock

## OPTIONAL EQUIPMENT

Battery 80V ■ 43.2 kWh ■ 540Ah  
Universal 110V Wall Charger  
Charger 80V ■ 100A  
Grammer® Suspension Seat  
Fingertip Controls  
Synchronized Steering  
Blue Light  
Rear Working Light  
Full or Partial Cab Enclosure



**BYD Motors LLC**

18910 S Wilmington Ave  
Rancho Dominguez, CA 90220

BYD Forklift production site is certified:  
**ISO 9001 ISO 14004 OHSAS 18001**

 1-800-293-2886

 [byd-forklifts.com](http://byd-forklifts.com)

 [sales@byd-forklifts.com](mailto:sales@byd-forklifts.com)