

ECB40/45/50

THE NEXT EVOLUTION OF FORKLIFTS

8,800 lbs - 11,000 lbs | 80V AC Motor | Zero Battery Maintenance | 10-year Battery Warranty



WORK SMARTER

With rapid, restriction-free charging, BYD forklifts operate across multiple shifts without the need to change or replace batteries. Built using iron-phosphate technology, each forklift includes a state-of-the-art Battery Management System and the longest battery warranty in the industry. With BYD, peace of mind is assured.

ECB40/45/50 Specifications

				ECB40	ECB45	ECB50
	Load capacity: rated load to 118" @ 24" LC		lb	8800	9900	11000
	Operating voltage		v	80 volts	80 volts	80 volts
	Drive Motors			Dual	Dual	Dual
Dimensions	Length to face of forks	l2	in	115.0	115.0	115.0
	Minimum turning radius	Wa	in	102.4	102.4	102.4
	Load distance, center wheel to face of forks	x	in	21.9	21.9	21.9
	Basic right-angle stack (add load and clearance)		in	124.2	124.2	124.2
	Overall width	b1	in	59.7	59.7	59.7
	Seat height	h7	in	49.6	49.6	49.6
	Overhead guard height	h6	in	92.2	92.2	92.2
	Carriage width	b3	in	57.1	57.1	57.1
	Carriage ITA Type			III	III	III
	Tilt range (forward/backward)		deg	6 / 8	6 / 8	6 / 8
	Ground clearance with load, below mast	m1	in	5.9	5.9	5.9
Performance	Travel speed (loaded/unloaded)		MPH	11 / 11	11 / 11	11 / 11
	Lift speed (loaded/unloaded)		FPM	70 / 90	70 / 90	70 / 90
	Lowering speed (loaded/unloaded)		FPM	100 / 80	100 / 80	100 / 80
	Max gradeability (loaded/unloaded)		%	20 / 20	20 / 20	20 / 20
Power System	Drive motor rating (S2=60 min)		KW	2x15	2x15	2x15
	Lift motor rating (S3=15% ED)		KW	25	25	25
	Battery capacity		KWh	43.2 / 64.8	43.2 / 64.8	43.2 / 64.8
	Charging time			2.6h / 4h	2.6h / 4h	2.6h / 4h
	Battery weight		lb	1985	1985	1985
Type of drive control			AC	AC	AC	
Weight	Service weight including battery		lb	14850	15466	16170
	Axle load, fully loaded (front/rear)		lb	20815 / 2888	22464 / 2959	24166 / 3064
	Axle load, unloaded (front/rear)		lb	7342 / 7541	7309 / 8191	7320 / 8886
Tires	Wheel size, front wheel or driving wheel		Spec	28*12.5-15	28*12.5-15	28*12.5-15
	Wheel size, rear wheel or supporting wheel		Spec	21*8-9	21*8-9	21*8-9
	Track width front	b10	in	47.87	47.87	47.87
	Track width rear	b11	in	44.49	44.49	44.49

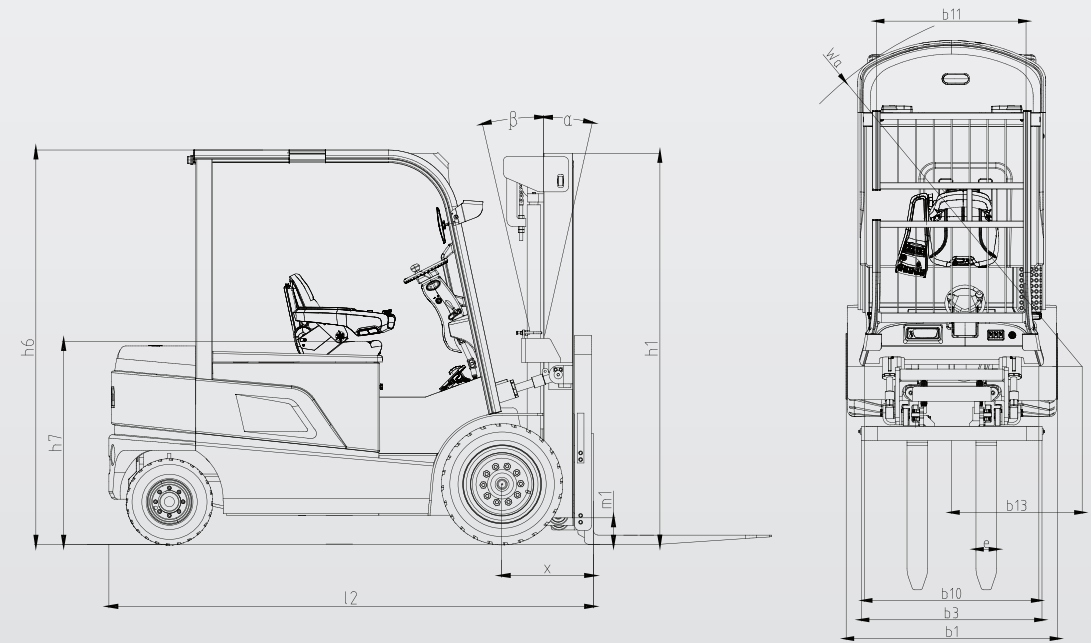

ECB40/45/50 Mast Specifications

Mast Specifications (in)	Fork Height	Free Lift	Collapsed Height	Extended Height	Fwd Tilt	Back Tilt	Capacity 24" LC		
							ECB40	ECB45	ECB50
2-Stage Standard Mast	118	6	93	167	6°	8°	8820	9923	11025
	130	6	98	179	6°	8°	8820	9702	10805
	138	6	102	187	6°	8°	8710	9526	10386
	157	6	112	207	6°	8°	8335	9107	9945
	177	6	122	226	6°	6°	7916	8688	9482
	197	6	132	246	6°	6°	7563	8291	9085
	217	6	142	266	6°	6°	7188	7916	8666
2-Stage FFL Mast	236	6	152	285	6°	6°	6858	7563	8291
	118	41	88	167	6°	8°	8820	9923	11025
	130	47	94	179	6°	8°	8820	9702	10805
	138	51	98	187	6°	8°	8710	9526	10386
	157	62	110	207	6°	8°	8335	9107	9945
3-stage FFL Mast	157	37	84	207	6°	6°	7982	8776	9592
	169	41	88	219	6°	6°	7762	8533	9349
	177	44	91	226	6°	6°	7607	8379	9173
	189	48	95	238	6°	6°	7409	8136	8930
	197	51	98	246	6°	6°	7254	7982	8754
	217	57	104	266	6°	6°	6858	7563	8313
	236	64	111	285	6°	6°	6527	7210	7938
	256	70	118	305	6°	3°	6218	6880	7607
	268	74	121	317	6°	3°	5976	6681	7387
295	85	132	344	6°	3°	5248	5865	6505	



ECB40/45/55

FEATURES

STANDARD EQUIPMENT

Iron Phosphate Battery Technology
Battery 80V ■ 43.2 kWh ■ 540Ah
Dual 80V AC Drive Motor
Regenerative Braking
LED Lights (Front ■ Rear ■ Strobe)
LCD Display
4-Way Hydraulic Valve
Rear Grab Handle with Horn
Rearview Mirrors
Ramp Hold Assist

STANDARD SAFETY FEATURES

Cornering Speed Reduction
Operator Presence Sensor (OPS)
Orange Seatbelt with Interlock

OPTIONAL EQUIPMENT

Battery 80V ■ 64.8 kWh ■ 810Ah
Universal 110V Wall Charger
Charger 80V ■ 100A
Grammer® Suspension Seat
Fingertip Controls
Synchronized Steering
Blue Light
Rear Working Light
Full or Partial Cab Enclosure



BYD Motors LLC

18910 S Wilmington Ave
Rancho Dominguez, CA 90220

BYD Forklift production site is certified:
ISO 9001 ISO 14004 OHSAS 18001

 1-800-293-2886

 byd-forklifts.com

 sales@byd-forklifts.com