

CLARK

OSQ

126/162/192



CLARK



CLARK: The Innovative and Durable Solution

The design, development, and manufacturing capabilities of CLARK, in combination with an unparalleled focus on customer support, a drive to understand fully each customer's needs in order to then supply the right solution, reflect the key essence of what is CLARK.

With over one million CLARK lift trucks sold around the world, each is a testament to the CLARK time-tested process of designing durable trucks with precise features that meet, if not exceed, the material handling needs of our customers. Our full range of dependable products – from pallet jacks to electric narrow aisle order selectors and up to our big 18,000lb capacity lift trucks – assures end-users CLARK has the solutions for their day-to-day needs.



These solutions built from industry innovations, from the nested I-Beam to a self-activating parking brake to new on-board diagnostics, began the same way: with the needs of our customers foremost in mind. By focusing on how we can improve our customers' material handling processes, we can assure our customers a lift truck designed to be the right solution for their needs.

When you bring it all together – an extensive research and development process, state-of-the-art manufacturing capabilities, and a superior dealership network – you have a company dedicated to delivering leading edge products for both today and far into the future. More reasons why CLARK is Built to Last®.

"CLARK, TOTALIFT, Powrworker, PartsPRO Plus, and Built to Last are registered in the U.S Patent and Trademark office. The "Hot Yellow Green" also known as "CLARK Green" is a trademark registered in the U.S Patent and Trademark office."



59-894-1400

CLARK MATERIAL HANDLING COMPANY
North American Headquarters
700 Enterprise Drive • Lexington, KY 40510
866-252-5275 • www.clarkmhc.com

OSQ 126/162/192
59-894-1400 Printed in USA OTP0222500
© 2022 CLARK Material Handling Company

STANDARD SPECIFICATIONS

OSQ

B dimension OSQ126 & OSQ162 = 45.2", OSQ192 = 49"
 G dimension OSQ126 & OSQ162 = 59", OSQ192 = 63.25"

MODEL #	MAST	LIFT HEIGHT	COL HEIGHT	EXTENDED HEIGHT	LOAD TRAY HEIGHT	WORKING HEIGHT	WEIGHT CHASSIS ONLY
		A	C	D	E	F	
OSQ126	Triple Stage	126	64.9	180.9	159.0	203	2268
OSQ162	Triple Stage	162	83.9	237.9	195.0	239	2610
OSQ192	Triple Stage	192	85.3	266.3	225.0	269	3160

Notes

Production engines and driveline components may vary in output and/or efficiency by $\pm 5\%$. The performance shown represents nominal values which may be obtained under typical operating conditions of a machine.

ANSI/ITSDF and Insurance Classification

Standard truck meets all applicable mandatory requirements of Part III-ANSI/ITSDF B56.1 Safety Standard for Powered Industrial Trucks and Underwriters Laboratories requirements as to fire hazard only for D and LP classifications.

For further information contact a CLARK representative.

Users should be aware of, and adhere to, applicable codes and regulations regarding operator training, use, operation and maintenance of powered industrial trucks, including:

- ANSI/ITSDF B56.1
- NFPA 505, fire safety standard for powered industrial trucks - type designations, areas of use, maintenance and operation.
- Occupational Safety and Health Administration (OSHA) regulations that may apply.

Contact your authorized CLARK forklift truck dealer for further information including operator training programs and auxiliary visual and audible warning systems, fire extinguishers, etc., as available for specific user applications and requirements. Specifications, equipment, technical data, photos and illustrations are based on information at time of printing and are subject to change without notice.

Some products may be shown with optional equipment.

Turning radius OSQ126 & OSQ162 = 52.5", OSQ192 = 56"

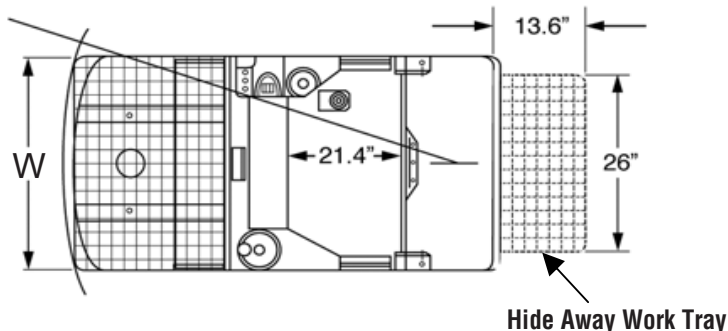

W dimension OSQ126 & OSQ162 = 31.5", OSQ192 = 34"



THE CLARK PartsPRO PLUS® SYSTEM

is our industry-leading electronic parts and service documentation tool that provides dealers with a quick and accurate method of identifying parts for every CLARK forklift built since 1961. PartsPRO® Plus ensures the availability of the most current technical information and has the unique capability to create parts manuals specific to your mixed CLARK fleet, making it simple to positively identify and order the correct part(s) from your local CLARK dealer. The right CLARK part—The First Time, Every Time.

Minimum Turn Aisle

Allow for additional clearance for ease of use.

OSQ126 & OSQ162 = 72", OSQ192 = 84"

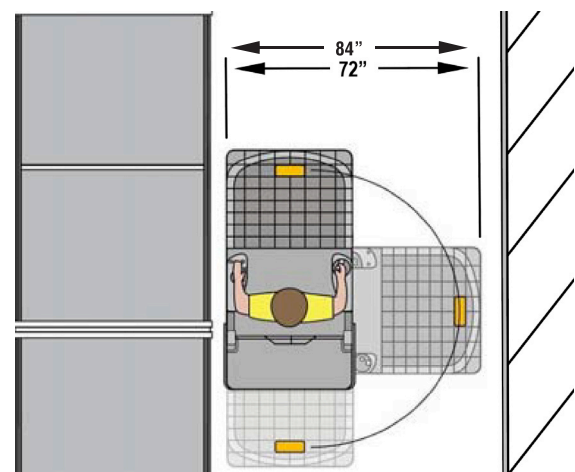

OSQ

CLARK OSQ Quick Pick

Representing an easier, safer and more productive upgrade from traditional rolling ladders, the CLARK OSQ, Order-Picker-Selector, maximizes productivity by combining the attributes of an elevated working platform, an order picker and a tugger into one compact vehicle design.

The OSQ delivers a smaller footprint and lower price tag than a typical order picker. The excellent stability at height and the ability to drive easily from task-to-task, makes the OSQ ready to make an immediate impact in any situation.

Operator Compartment

- 9.5" step-height provides easy access to a roomy operator compartment
- Fingertip controls for travel, lift and lower functions allow for intuitive steering
- Two side rails enclose the compartment while the truck is in operation
- Wire-mesh front work platform provides strength and excellent visibility
- Large storage compartment for quick tool and various item placement
- Convenient hide-away tray at rear of truck with 200 lb capacity

Strength and Performance

- Robust frame design with up to 1000 lb capacity including a 500 lb capacity work platform
- Motor and pump powered by a 24-volt, 224AH AGM Battery
- Fully charged battery delivers up to 4 hours of operation on a single charge
- 120VAC internal battery charger plugs into any standard wall outlet
- Standard top speed of 3.4 mph when lift is below 24"
- Designed to accommodate and lift operators of up to 300 lbs.



OSQ



Componentry

- ZAPI dashboard with fault code diagnostics, hour-meter, battery charge state, travel speed and drive wheel directional indicators
- Variable forward and reverse travel, powered lift and lower, and an electric horn
- 24-volt AC system manages vehicle's electronic power steering, acceleration, braking and automatic speed reduction – both at height and during tight cornering
- AC Drive motor provides high torque throughout the entire drive range
- Regenerative braking engages when the operator's hand is removed from the travel control

Safety and Productivity

- Heavy-duty I-beam design provides excellent stability at height
- Steel mast channels and side mounted lift cylinders for increased platform capacity
- Powerhead mounted stability casters increase truck stability throughout lift range
- Electronic power steering with a 180° steering arc delivers high maneuverability
- Single speed lift and lower controls promote efficiency and safety
- Improved productivity and safety compared to traditional rolling ladders

Easy Maintenance

- Removable cover with a CAN-bus system for easy maintenance
- Drive unit, steer motor and hydraulic pump & reservoir centrally located for clear access
- ZAPI ACO travel and EPS ACO steering controllers serviced using the ZAPI Smart handset
- Robust components and common design mean less downtime and more time operating
- Brushless AC Technology drastically reduces maintenance and extends battery range
- Fully charged battery after approximately 7.5 hours with available opportunity charging

GENERAL DATA & STANDARD DIMENSIONS

CAPACITY

Elevation	Operator Compartment	Front Work Platform	Rear "Hide-Away" Tray
126"	300 lbs	500 lbs	200 lbs
162"	300 lbs	150 lbs	200 lbs
192"	300 lbs	100 lbs	200 lbs

BATTERY COMPARTMENTS

OSQ126 & OSQ162: 29.1" x 7.9" x open

OSQ192: 29.1" x 11" x open

SPEED

24-volt ZAPI AC-0 travel controller with 4 operator selectable travel settings and turtle speed mode. Standard travel speeds are variable from 0 to 3.4 mph with a high speed option available for ground level travel of up to 5 mph. Lift speed up to 42 fpm.

WEIGHT

2,268 lbs to 3,160 lbs chassis only

TIRES / WHEELS

DRIVE

9" x 3" polyurethane

LOAD

8" x 3" rubber

STABILITY

3" x 2" polyurethane

