

# S SERIES



**S25**  
20/25/30/35



Max Load Capacity  
4000 / 5000 / 6000 / 7000 lbs.  
(2000 / 2500 / 3000 / 3500 kg)



## Upright Table

	Maximum Fork Height in mm	Overall Height <sup>1</sup> Lowered in mm	Free Lift <sup>3</sup> in mm	Standard Tilt Spec <sup>2</sup> B°/F°		
<b>S20/25 Standard</b>						
83	2120	62.0	1575	4.3	110	6/10
117	2980	78.9	2005	4.3	110	8/10
• 130	3300	85.2	2165	4.3	110	10/8
138	3500	90.7	2305	4.3	110	10/8
147	3725	96.7	2455	4.3	110	10/8
152	3860	99.6	2530	4.3	110	10/8
164	4165	110.2	2800	4.3	110	5/6
172	4380	118.1	3000	4.3	110	5/6
182	4620	127.2	3230	4.3	110	5/6
204	5170	137.6	3495	4.3	110	5/3

	Maximum Fork Height in mm	Overall Height <sup>1</sup> Lowered in mm	Free Lift <sup>3</sup> in mm	Standard Tilt Spec <sup>2</sup> B°/F°		
<b>S30 Standard</b>						
83	2120	62.6	1590	4.3	110	6/10
117	2980	79.5	2020	4.3	110	8/10
• 130	3300	85.8	2180	4.3	110	10/8
138	3500	91.3	2320	4.3	110	10/8
147	3725	97.2	2470	4.3	110	10/8
152	3860	100.2	2545	4.3	110	10/8
164	4165	110.8	2815	4.3	110	5/6
172	4380	118.7	3015	4.3	110	5/6
182	4620	127.8	3245	4.3	110	5/6
204	5170	138.2	3510	4.3	110	5/3

	Maximum Fork Height in mm	Overall Height <sup>1</sup> Lowered in mm	Free Lift <sup>3</sup> in mm	Standard Tilt Spec <sup>2</sup> B°/F°		
<b>S35 Standard</b>						
78	1985	63.4	1610	4.5	115	6/10
112	2845	80.3	2040	4.5	115	8/10
• 125	3165	86.6	2200	4.5	115	10/8
132	3365	92.1	2340	4.5	115	10/8
141	3590	98.0	2490	4.5	115	10/8
147	3725	101.0	2565	4.5	115	10/8
159	4030	111.6	2835	4.5	115	5/6
167	4245	119.5	3035	4.5	115	5/6
177	4485	128.5	3265	4.5	115	5/6
198	5035	139.0	3530	4.5	115	5/3

	Maximum Fork Height in mm	Overall Height <sup>1</sup> Lowered in mm	Free Lift <sup>3</sup> in mm	Standard Tilt Spec <sup>2</sup> B°/F°		
<b>S20/25 Triple Stage</b>						
• 170	4320	78.9	2005	30.9	786	5/6
177	4500	81.3	2065	33.3	846	5/6
189	4800	85.2	2165	37.2	946	5/6
205	5210	90.7	2305	42.8	1086	5/3
217	5520	96.7	2455	48.7	1236	5/3
226	5740	99.6	2530	51.6	1311	5/3
240	6100	105.9	2690	57.9	1471	5/3
251	6370	110.2	2800	62.2	1581	3/3
269	6830	118.1	3000	70.1	1781	3/3
288	7315	127.2	3230	79.2	2011	3/3

	Maximum Fork Height in mm	Overall Height <sup>1</sup> Lowered in mm	Free Lift <sup>3</sup> in mm	Standard Tilt Spec <sup>2</sup> B°/F°		
<b>S30 Triple Stage</b>						
170	4320	79.5	2020	31.5	801	5/6
177	4500	81.9	2080	33.9	861	5/6
• 189	4800	85.8	2180	37.8	961	5/6
205	5210	91.3	2320	43.3	1101	5/3
217	5520	97.2	2470	49.3	1251	5/3
226	5740	100.2	2545	52.2	1326	5/3
240	6100	106.5	2705	58.5	1486	5/3
251	6370	110.8	2815	62.8	1596	3/3
269	6830	118.7	3015	70.7	1796	3/3
288	7315	127.8	3245	79.8	2026	3/3

	Maximum Fork Height in mm	Overall Height <sup>1</sup> Lowered in mm	Free Lift <sup>3</sup> in mm	Standard Tilt Spec <sup>2</sup> B°/F°		
<b>S35 Triple Stage</b>						
163	4140	80.3	2040	32.3	821	5/6
170	4320	82.7	2100	34.7	881	5/6
• 182	4620	86.6	2200	38.6	981	5/6
198	5030	92.1	2340	44.1	1121	5/6
210	5340	98.0	2490	50.0	1271	5/3
219	5560	101.0	2565	53.0	1346	5/3
233	5920	107.3	2725	59.3	1506	5/3
244	6190	111.6	2835	63.6	1616	5/3
262	6650	119.5	3035	71.5	1816	3/3
281	7135	128.5	3265	80.6	2046	3/3

• Indicates preferred common specification.  
 1 For overall height raised with load backrest, add 48 in. (1220 mm) to maximum fork height.  
 2 Standard tilt shown. Contact CLARK representative for information on optional tilt.  
 3 Free lift dimensions shown are without load backrest.  
 Other uprights available, contact a Clark representative.

**Notes**  
 Production engines and driveline components may vary in output and/or efficiency by ±5%. The performance shown represents nominal values which may be obtained under typical operating conditions of a machine.

## Upright Table

	Maximum Fork Height in mm	Overall Height <sup>1</sup> Lowered in mm	Free Lift <sup>3</sup> in mm	Standard Tilt Spec <sup>2</sup> B°/F°		
<b>S20/25 Hi-Lo</b>						
115	2935	78.9	2005	30.9	786	6/8
• 128	3255	85.2	2165	37.2	946	6/8
139	3530	90.7	2305	42.8	1086	6/8
148	3760	96.7	2455	48.7	1236	6/8
154	3910	99.6	2530	51.6	1311	6/8

	Maximum Fork Height in mm	Overall Height <sup>1</sup> Lowered in mm	Free Lift <sup>3</sup> in mm	Standard Tilt Spec <sup>2</sup> B°/F°		
<b>S30 Hi-Lo</b>						
115	2935	79.5	2020	31.5	801	6/8
• 128	3255	85.8	2180	37.8	961	6/8
139	3530	91.3	2320	43.3	1101	6/8
148	3760	97.2	2470	49.3	1251	6/8
154	3910	100.2	2545	52.2	1326	6/8

	Maximum Fork Height in mm	Overall Height <sup>1</sup> Lowered in mm	Free Lift <sup>3</sup> in mm	Standard Tilt Spec <sup>2</sup> B°/F°		
<b>S20/25/30 Quad</b>						
• 240	6100	85.2	2165	37.2	946	5/3
258	6560	90.9	2310	43.0	1091	3/3
276	7015	97.0	2463	49.0	1244	3/3
294	7480	103.0	2616	55.0	1397	3/3
312	7935	109.0	2768	61.0	1549	3/3

	Maximum Fork Height in mm	Overall Height <sup>1</sup> Lowered in mm	Free Lift <sup>3</sup> in mm	Standard Tilt Spec <sup>2</sup> B°/F°		
<b>S30 Quad</b>						
• 240	6100	85.8	2180	37.8	961.0	5/3
258	6560	91.5	2325	43.5	1106	3/3
276	7015	97.6	2478	49.6	1259	3/3
294	7480	103.6	2631	55.6	1412	3/3
312	7935	109.6	2783	61.6	1564	3/3

	Maximum Fork Height in mm	Overall Height <sup>1</sup> Lowered in mm	Free Lift <sup>3</sup> in mm	Standard Tilt Spec <sup>2</sup> B°/F°		
<b>S35 Quad</b>						
• 240	6100	86.6	2200	38.6	981	5/3
258	6560	91.5	2325	44.3	1126	3/3
276	7015	97.6	2478	50.4	1279	3/3
294	7480	103.6	2631	56.4	1432	3/3
312	7935	109.6	2783	62.4	1584	3/3

	Model	A%	B%
<b>Grade Clearance</b>			
S20		60.1	42.0
S25		50.0	42.0
S30		57.7	46.8
S35		57.7	48.6

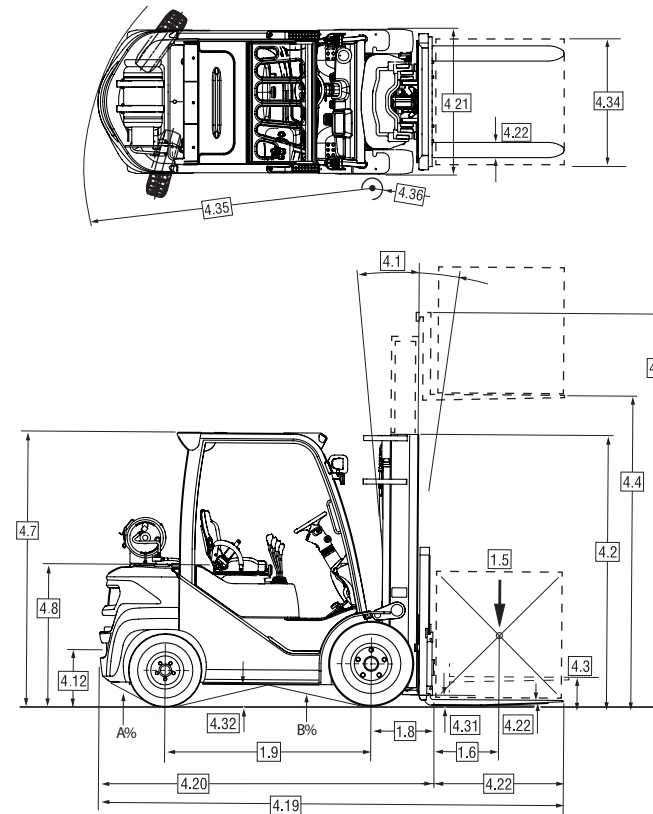

For corresponding data see Specification Chart

# S SERIES

SMART · STRONG · SAFE

Building on over 100 years of lift truck innovations, design and industry firsts. The evolution continues... the CLARK S-Series the next generation of lift trucks.



\*Shown with optional cabin

## SMART

Our design standards have historically led the industry in innovation and firsts; the S-Series represents the next phase of lift truck design.

- Interactive Dash
- Built in reporting of truck and operator performance via optional telemetric
- Engine/Powertrain protection
- Integrated systematic service tools
- On-board reporting of operator controlled functions

## STRONG

CLARK trucks are "Built to Last." From our industrial design to our legacy Dealers our combined strengths ensure a strong performance to your bottom line and overall lower cost of ownership.

- Force-cooled Wet Disc Brakes
- Fully welded heavy gauge frame
- Nested I-beam upright
- 6 Roller Carriage
- External Side-thrust rollers
- Proven steer axles and cooling systems

## SAFE

CLARK makes your safety your priority. Safety is and has been a cornerstone of CLARK design standards for over 100 years. Our standards became the industry standards. The S-Series innovates again with standard features including:

- Automatically-applied Parking Brake.
- Speed Limit Control
- Increased visibility
- Optional Rear View Camera.
- High-visibility Orange Seat Belt
- Designed with optimal center-of-gravity to enhance truck stability.



SMART · STRONG · SAFE

# Standard Specifications S-Series Pneumatic Isuzu Diesel Engine

# Standard Specifications S-Series Pneumatic Ford L.P.Gas Engine

Specifications	1.1	Manufacturer	S-Series ISUZU Tier4				1.1	Manufacturer	S-Series L.P.Gas FORD Tier4			
	1.2	Manufacturer's designation	S20D	S25D	S30D	S35D	1.2	Manufacturer's designation	S20L	S25L	S30L	S35L
	1.3	Drive unit Diesel, L.P. Gas	Diesel	Diesel	Diesel	Diesel	1.3	Drive unit Diesel, L.P. Gas	L.P. Gas	L.P. Gas	L.P. Gas	L.P. Gas
Weight	1.4	Operator type stand on / driver seated	Driver Seated	Driver Seated	Driver Seated	Driver Seated	1.4	Operator type stand on / driver seated	Driver Seated	Driver Seated	Driver Seated	Driver Seated
	1.5	Load capacity / rated load	lbs(kg) 4000 (2000)	5000 (2500)	6000 (3000)	7000 (3500)	1.5	Load capacity / rated load	lbs(kg) 4000 (2000)	5000 (2500)	6000 (3000)	7000 (3500)
	1.6	Load center distance	in(mm) 24 (500)	24 (500)	24 (500)	24 (500)	1.6	Load center distance	in(mm) 24 (500)	24 (500)	24 (500)	24 (500)
Tires	1.8	Load center distance, center of drive axle to fork face	in(mm) 18.3 (465)	18.3 (465)	18.7 (475)	19.5 (495)	1.8	Load center distance, center of drive axle to fork face	in(mm) 18.3 (465)	18.3 (465)	18.7 (475)	19.5 (495)
	1.9	Wheelbase	in(mm) 65.0 (1650)	65.0 (1650)	66.9 (1700)	66.9 (1700)	1.9	Wheelbase	in(mm) 65.0 (1650)	65.0 (1650)	66.9 (1700)	66.9 (1700)
	2.1	Service weight	lbs(kg) 7,573 (3435)	8,320 (3774)	9,354 (4243)	10,252 (4650)	2.1	Service weight	lbs(kg) 7,363 (3340)	8,111 (3679)	9,147 (4149)	10,040 (4554)
Dimensions	2.2	Axle loading, loaded front / rear	lbs(kg) 10,452 / 1,533 (4740 / 695)	12,046 / 1,786 (5463 / 810)	13,922 / 2,048 (6314 / 929)	15,759 / 2,212 (7147 / 1003)	2.2	Axle loading, loaded front / rear	lbs(kg) 10,595 / 1,177 (4806 / 534)	12,187 / 1,435 (5528 / 651)	14,050 / 1,711 (6373 / 776)	15,882 / 1,874 (7204 / 850)
	2.3	Axle loading, unloaded front / rear	lbs(kg) 3,462 / 4,112 (1570 / 1865)	3,310 / 5,012 (1501 / 2273)	3,515 / 5,843 (1594 / 2650)	3,524 / 6,730 (1598 / 3052)	2.3	Axle loading, unloaded front / rear	lbs(kg) 3,607 / 3,757 (1636 / 1704)	3,452 / 4,702 (1566 / 2133)	3,644 / 5,503 (1653 / 2496)	3,651 / 6,391 (1656 / 2899)
	3.1	Tire type, P = pneumatic, SE = solid pneu <sup>1</sup>	P	P	P	P	3.1	Tire type, P = pneumatic, SE = solid pneu <sup>1</sup>	P	P	P	P
	3.2	Tire size, front	7.00x12-14PR	7.00x12-14PR	28x9x15-14PR	250x15-20PR	3.2	Tire size, front	7.00x12-14PR	7.00x12-14PR	28x9x15-14PR	250x15-20PR
	3.3	Tire size, rear	6.00x9-10PR	6.00x9-10PR	6.50x10-12PR	6.50x10-12PR	3.3	Tire size, rear	6.00x9-10PR	6.00x9-10PR	6.50x10-12PR	6.50x10-12PR
	3.5	Wheels, number front/rear (x = drive wheels)	2x / 2	2x / 2	2x / 2	2x / 2	3.5	Wheels, number front/rear (x = drive wheels)	2x / 2	2x / 2	2x / 2	2x / 2
	3.6	Tread, front	in(mm) 37.9 (964)	37.9 (964)	39.3 (999)	39.6 (1005)	3.6	Tread, front	in(mm) 37.9 (964)	37.9 (964)	39.3 (999)	39.6 (1005)
	3.7	Tread, rear	in(mm) 38.2 (970)	38.2 (970)	38.2 (970)	38.2 (970)	3.7	Tread, rear	in(mm) 38.2 (970)	38.2 (970)	38.2 (970)	38.2 (970)
	4.1	Tilt of upright/fork carriage, back / forward	deg. 10B / 8F	10B / 8F	10B / 8F	10B / 8F	4.1	Tilt of upright/fork carriage, back / forward	deg. 10B / 8F	10B / 8F	10B / 8F	10B / 8F
	4.2	Height, upright lowered	in(mm) 85.2 (2165)	85.2 (2165)	85.8 (2180)	86.6 (2200)	4.2	Height, upright lowered	in(mm) 85.2 (2165)	85.2 (2165)	85.8 (2180)	86.6 (2200)
	4.3	Freelift	in(mm) 4.3 (110)	4.3 (110)	4.3 (110)	4.5 (115)	4.3	Freelift	in(mm) 4.3 (110)	4.3 (110)	4.3 (110)	4.5 (115)
	Performance	4.4	Lift height <sup>2</sup>	in(mm) 130 (3300)	130 (3300)	130 (3300)	125 (3165)	4.4	Lift height <sup>2</sup>	in(mm) 130 (3300)	130 (3300)	130 (3300)
4.5		Height, upright extended <sup>6</sup>	in(mm) 154.5 (3924)	154.5 (3924)	156.2 (3967)	154.1 (3913)	4.5	Height, upright extended <sup>6</sup>	in(mm) 154.5 (3924)	154.5 (3924)	156.2 (3967)	154.1 (3913)
4.7		Height overhead guard (cab)	in(mm) 85.2 (2165)	85.2 (2165)	85.8 (2180)	86.6 (2200)	4.7	Height overhead guard (cab)	in(mm) 85.2 (2165)	85.2 (2165)	85.8 (2180)	86.6 (2200)
4.8		Seat height	in(mm) 45.6 (1157)	45.6 (1157)	46.1 (1172)	46.1 (1172)	4.8	Seat height	in(mm) 45.6 (1157)	45.6 (1157)	46.1 (1172)	46.1 (1172)
4.12		Coupling height	in(mm) 16.1 (410)	16.1 (410)	16.7 (425)	16.7 (425)	4.12	Coupling height	in(mm) 16.1 (410)	16.1 (410)	16.7 (425)	16.7 (425)
4.19		Overall length	in(mm) 143.3 (3639)	146.1 (3710)	151.2 (3840)	154.3 (3920)	4.19	Overall length	in(mm) 143.3 (3639)	146.1 (3710)	151.2 (3840)	154.3 (3920)
4.20		Length to face of forks	in(mm) 101.1 (2569)	103.9 (2640)	109.1 (2770)	112.2 (2850)	4.20	Length to face of forks	in(mm) 101.1 (2569)	103.9 (2640)	109.1 (2770)	112.2 (2850)
4.21		Width Tires	in(mm) 45.7 (1160)	45.7 (1160)	48.1 (1220)	48.9 (1242)	4.21	Width Tires	in(mm) 45.7 (1160)	45.7 (1160)	48.1 (1220)	48.9 (1242)
4.22		Fork dimensions	in(mm) 1.75x4x42 (45x100x1070)	1.75x4x42 (45x100x1070)	1.75x4.8x42 (45x122x1070)	2.0x5x42 (50x125x1070)	4.22	Fork dimensions	in(mm) 1.75x4x42 (45x100x1070)	1.75x4x42 (45x100x1070)	1.75x4.8x42 (45x122x1070)	2.0x5x42 (50x125x1070)
4.23		Fork carriage, ITA	CLASS II	CLASS II	CLASS III	CLASS III	4.23	Fork carriage, ITA	CLASS II	CLASS II	CLASS III	CLASS III
4.24		Fork carriage width	in(mm) 41 (1041)	41 (1041)	41 (1041)	45.1 (1145)	4.24	Fork carriage width	in(mm) 41 (1041)	41 (1041)	41 (1041)	45.1 (1145)
Drive Line		4.31	Ground clearance minimum, loaded	in(mm) 5.3 (135)	5.3 (135)	5.9 (150)	6.7 (170)	4.31	Ground clearance minimum, loaded	in(mm) 5.3 (135)	5.3 (135)	5.9 (150)
	4.32	Ground clearance center of wheelbase	in(mm) 6.1 (155)	6.1 (155)	6.7 (170)	6.7 (170)	4.32	Ground clearance center of wheelbase	in(mm) 6.1 (155)	6.1 (155)	6.7 (170)	6.7 (170)
	4.34	Right Angle Stack (Add Load Length and Clearance)	in(mm) 107.5 (2730)	110 (2795)	115.2 (2925)	118 (2997)	4.34	Right Angle Stack (Add Load Length and Clearance)	in(mm) 107.5 (2730)	110 (2795)	115.2 (2925)	118 (2997)
	4.35	Turning radius (truck)	in(mm) 89.2 (2265)	91.7 (2330)	96.5 (2450)	98.5 (2502)	4.35	Turning radius (truck)	in(mm) 89.2 (2265)	91.7 (2330)	96.5 (2450)	98.5 (2502)
	4.36	Inside turning radius	in(mm) 29.2 (741)	29.2 (741)	29.6 (751)	29.6 (751)	4.36	Inside turning radius	in(mm) 29.2 (741)	29.2 (741)	29.6 (751)	29.6 (751)
	5.1	Travel speed loaded / unloaded	mph(km/h) 10.3 (16.6) / 11.0 (17.7)	10.1 (16.3) / 10.9 (17.6)	10.9 (17.5) / 11.5 (18.6)	11.8 (19) / 12.0 (19.3)	5.1	Travel speed loaded / unloaded	mph(km/h) 10.7 (17.2) / 11.4 (18.3)	10.4 (16.8) / 11.3 (18.2)	11.2 (18.1) / 11.9 (19.3)	11.2 (18.1) / 11.6 (18.7)
5.2	Lift speed loaded / unloaded	fpm(m/s) 108.2 (0.55) / 114.1 (0.58)	108.2 (0.55) / 114.1 (0.58)	108.2 (0.55) / 114.1 (0.58)	88.6 (0.45) / 94.5 (0.48)	5.2	Lift speed loaded / unloaded	fpm(m/s) 102.4 (0.52) / 106.3 (0.54)	102.4 (0.52) / 106.3 (0.54)	102.4 (0.52) / 106.3 (0.54)	84.6 (0.43) / 88.6 (0.45)	
5.3	Lowering speed loaded / unloaded	fpm(m/s) 108.2 (0.55) / 98.4 (0.50)	108.2 (0.55) / 98.4 (0.50)	108.2 (0.55) / 98.4 (0.50)	92.5 (0.47) / 84.6 (0.43)	5.3	Lowering speed loaded / unloaded	fpm(m/s) 108.2 (0.55) / 98.4 (0.50)	108.2 (0.55) / 98.4 (0.50)	108.2 (0.55) / 98.4 (0.50)	92.5 (0.47) / 84.6 (0.43)	
5.6	Max. drawbar pull loaded / unloaded <sup>3,4</sup>	lbf(N) 5172 (23,006) / 1675.5 (7,453)	5214 (23,193) / 1583 (7,042)	4747 (21,116) / 1660 (7,384)	4354 (19,368) / 1660 (7,384)	5.6	Max. drawbar pull loaded / unloaded <sup>3,4</sup>	lbf(N) 4762 (21,182) / 1751 (7,789)	4795 (21,329) / 1656 (7,366)	4361 (19,399) / 1742 (7,749)	4239 (18,856) / 1731 (7,670)	
5.8	Max. gradeability loaded / unloaded <sup>3,4</sup>	% 47.6 / 23.2	40.7 / 20.2	31.1 / 19.0	25.0 / 17.5	5.8	Max. gradeability loaded / unloaded <sup>3,4</sup>	% 44.2 / 24.8	37.6 / 21.4	28.8 / 20.3	24.6 / 18.5	
5.10	Service brake	WET	WET	WET	WET	5.10	Service brake	WET	WET	WET	WET	
Drive Line	7.1	Manufacturer / Type	ISUZU / 4LE2X	ISUZU / 4LE2X	ISUZU / 4LE2X	ISUZU / 4LE2X	7.1	Manufacturer / Type	FORD / FORD2.5	FORD / FORD2.5	FORD / FORD2.5	FORD / FORD2.5
	7.2	Rated output acc. to SAE J 1349	HP(kW) 61.7 (46)	61.7 (46)	61.7 (46)	61.7 (46)	7.2	Rated output acc. to SAE J 1349	HP(kW) 69.7 (52)	69.7 (52)	69.7 (52)	69.7 (52)
	7.3	Rated speed	rpm 2400	2400	2400	2400	7.3	Rated speed	rpm 2500	2500	2500	2500
	7.4	No. of cylinders / displacement	/in <sup>3</sup> (cm <sup>3</sup> ) 4 / 133 (2179)	4 / 133 (2179)	4 / 133 (2179)	4 / 133 (2179)	7.4	No. of cylinders / displacement	/in <sup>3</sup> (cm <sup>3</sup> ) 4 / 152 (2488)	4 / 152 (2488)	4 / 152 (2488)	4 / 152 (2488)
8.2	Operating pressure for attachments	bar Adjustable	Adjustable	Adjustable	Adjustable	8.2	Operating pressure for attachments	bar Adjustable	Adjustable	Adjustable	Adjustable	
8.4	Sound level, driver's ear <sup>5</sup>	dB (A) 81	81	81	81	8.4	Sound level, driver's ear <sup>5</sup>	dB (A) 79	79	79	79	

## Operator Comfort and Productivity



- Minimal vibration and noise to the operator via a balanced engine and isolated transmission
- Adjustable full-suspension seat
- Hood-mounted levers with low input force
- Large floorboard improves legroom and boot clearance
- Small diameter steering wheel with low steering effort
- Reduced brake and inching pedal effort
- Infinitely adjustable tilt steering column
- Optimized step height

## Smart Dash



- 5" color LCD display
- On-board diagnostics
- Canbus communication
- Password protected engine start through dash
- Powertrain protection monitoring system

### ANSI/ITSDF and Insurance Classification

Standard truck meets all applicable mandatory requirements of Part III-ANSI/ITSDF B56.1 Safety Standard for Powered Industrial Trucks and Underwriters Laboratories requirements as to fire hazard only for D and LP classifications. For further information contact a Clark representative. Users should be aware of, and adhere to, applicable codes and regulations regarding operator training, use, operation and maintenance of powered industrial trucks, including:

- ANSI/ITSDF B56.1
- NFPA 505, fire safety standard for powered industrial trucks - type designations, areas of use, maintenance and operation.

- Occupational Safety and Health Administration (OSHA) regulations that may apply.

Contact your authorized CLARK forklift truck dealer for further information including operator training programs and auxiliary visual and audible warning systems, fire extinguishers, etc., as available for specific user applications and requirements.

Specifications, equipment, technical data, photos and illustrations are based on information at time of printing and are subject to change without notice. Some products may be shown with optional equipment.

# S SERIES



### & Don't Forget... Safety Starts With You!

#### Before operating a lift truck, an operator must:

- Be trained and authorized
- Read and understand operator's manual
- Not operate a faulty lift truck
- Not repair a lift truck unless trained and authorized
- Have the overhead guard and load backrest extension in place
- Perform daily inspections

#### During operation, a lift truck operator must:

- Wear a seat belt
- Keep entire body inside truck cab
- Never carry passengers or lift people
- Keep truck away from people and obstructions
- Travel with lift mechanism as low as possible and tilted back
- Allow safe stopping distance and come to a complete stop before leaving operator compartment

#### To park a lift truck, an operator must:

- Completely lower forks or attachments
- Shift into neutral
- Turn key off
- Set parking brake

## Low Cost of Ownership



- 500 hour oil service interval on FORD and Isuzu engines
- 2,000 hour oil service interval on transmission (for general warehouse)
- Optimized hydraulic operating pressure reduces fuel consumption
- Separate transmission and axle simplify servicing
- Open core radiator is standard
- Engine efficiency/performance reduces fuel consumption
- DOC (Diesel Oxidation Catalyst)
- Force cooled wet disc brakes

## High Performance Engines

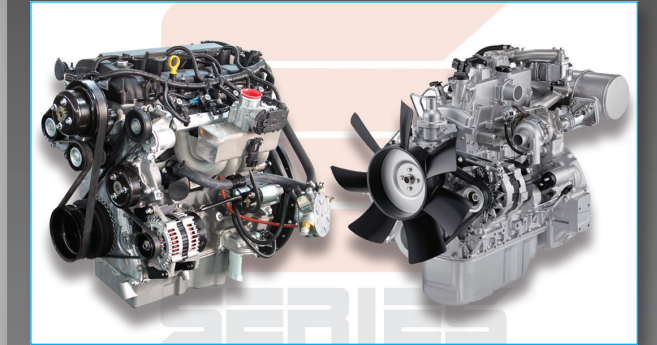

### FORD 2.5L LPG Tier-4 Final

- Balanced engine
- 4-cylinder dual overhead cam design
- VVT (Variable Valve Timing)
- Sequential multi-port fuel injection
- Timing chain-driven camshaft
- Automatic belt tensioner

### ISUZU 4LE2X 2.2L Diesel Tier-4 Final

- Turbo-charged
- High-pressure multi-stage injection
- DOC (Diesel Oxidation Catalyst)
- No regeneration (burn-off) cycles necessary
- No UREA additives

SMART • STRONG • SAFE



## 100 YEARS OF MATERIAL HANDLING INNOVATION

A Centennial is an important milestone which not only celebrates longevity, but testifies to the strength of the CLARK brand across generations. This is reflected in the more than one million lift trucks manufactured by CLARK Material Handling Company over the past 100 years. Even more powerful than the number of trucks built is the company's legacy of innovation. It began in 1917 when employees of CLARK Equipment Company constructed a simple three-wheeled shop buggy to haul sand and castings between buildings at their Buchanan, Michigan plant. The "Trutractor" as the shop buggy was named, became



the first internal combustion material handling truck and was a great success. The industrial truck was born and in the process CLARK developed the first hydraulic lift. Through the years, many extraordinary inventions followed, among them the nested I-beam upright, overhead guard and operator restraint system. The founding principles of Eugene B. Clark are still true: "Aim always to build the best; never be content with just as good." Today the company remains focused on a bright future and the technologies and trends driving the material handling industry around the world. One Purpose, One Brand, One Legacy, One Century.

