

CLARK

S25-35XE

RENEGADE

LI-ION



⚡ **S SERIES** ⚡
25/30/35

Max Load Capacity
5000/6000/7000 lbs.
(2268/2722/3175 kg)

OVERVIEW

01

POWER, PERFORMANCE,
AND STYLEMeet the All-New Lithium-Powered
S25–35XE RENEGADE

The CLARK RENEGADE isn't just another electric forklift—it's a revolution. Built to rival the performance of internal combustion trucks, it delivers equal or better performance with zero emissions, lower total cost of ownership, and a fresh, head-turning design that stands out anywhere. Indoors or outdoors, in the yard or in the warehouse, the RENEGADE thrives where others compromise.

Models Available:

S25XE	5,000 lb. capacity
S30XE	6,000 lb. capacity
S35XE	7,000 lb. capacity

Lithium Power. IC Performance.
Zero Emissions

The RENEGADE is built to replace IC trucks without sacrificing capability. Travel, lift, and lower speeds match or exceed traditional IC trucks, while delivering the added benefits of clean, quiet operation and lower total cost of ownership.

Performance Comparison (Unloaded):

METRIC	RENEGADE (Electric)	S25L (IC)
Travel Speed	11 mph	11 mph
Lift Speed	106 fpm	106 fpm
Lower Speed	98 fpm	98 fpm
Drawbar Pull	2,456 lbf	1,656 lbf

FEATURE

02

LOWER OPERATING COSTS.
HIGHER REWARDS.

Go electric and save big. With fuel savings, reduced maintenance, and fewer moving parts, the RENEGADE can lower your total cost of ownership by 20% or more compared to IC (Internal Combustion) trucks, especially in high-use applications. Lithium-powered forklifts offer significant advantages over internal combustion and lead-acid models, delivering lower operating costs through cheaper electricity versus traditional fuel, elimination of oil changes and engine-related maintenance, and reduced battery service needs.

*Performance and cost-savings claims are based on internal testing and may vary depending on application, operating conditions, and maintenance practices. CLARK makes no express or implied warranty of performance.



Built for Indoor or Outdoor use

The RENEGADE is more than a warehouse solution—it's ready for the yard. With excellent ground clearance, gradeability, and full weatherproofing options, it excels in rugged environments.

Outdoor Capability Highlights:

FEATURE	RENEGADE (Electric)	S25L (LPG)
Ground Clearance	6.1"	6.1"
Climbing Grade	27%	21%
Cab/Heater/AC Options	Available	Available
Tires (Front/Rear)	7.00-12/6.00-9	7.00-12/6.00-9

FEATURE
03

BUILT FOR THE OUTDOORS

Why limit electric forklifts to indoor work? With 6.1" ground clearance, 27% gradeability, and weather-protected components, the RENEGADE goes where IC trucks go, without the fuel bill. Pneumatic-style tires (7.00-12 front, 6.00-9 rear) deliver traction and stability in any yard or dock environment.



FEATURE
04

STAND-OUT STYLING

The famous CLARK "S Series Style" meets the future of electric power. Polygonal contours, a low-profile counterweight for better visibility, and reflective rear accents create a dynamic, recognizable look that's as functional as it is striking.

FEATURE
06

GO ELECTRIC WITHOUT
COMPROMISE

Travel speeds up to 11 mph, lift/lower speeds of 106/98 fpm, and a drawbar pull of 2,456 lbf mean you won't miss your IC truck, except at the fuel pump. Clean, quiet, and powerful, the RENEGADE delivers the muscle you need with the efficiency you want.



CLARK FUSION™ Lithium Power: Cleaner. Smarter. Stronger.

Replace your lead-acid system and eliminate the need for charging rooms, maintenance contracts, and mid-shift battery swaps. With CLARK FUSION™, electric never felt so effortless.

FEATURE
07

CLARK FUSION LITHIUM –
POWERING THE FUTURE

An 80V / 410AH UL-certified lithium battery fuels the RENEGADE, delivering consistent full power from start to finish, with no performance fade. Run up to 8 hours on a single charge, or two shifts with opportunity charging, and recharge in as little as 2 hours with no cooling time.

No watering. No acid spills. No maintenance contracts. Just plug in and go. Optional onboard charging means quick boosts anywhere you have power, no dedicated charging room required. CLARK Fusion batteries last 2–3 times longer than lead-acid, cutting battery costs by up to 50%.



Longer Run Time. Less Downtime.

- 80V / 410AH UL-Certified Battery
- Up to 8 hours of use in regular mode

Fast, Convenient Charging

- 200A UL-listed charger
- Optional on-board charger
- Easy-access charging port
- No need for an expensive dedicated charging room

FEATURE
08

DESIGNED FOR COMFORT.
BUILT FOR PERFORMANCE.

From the moment an operator steps in, the RENEGADE feels right. A spacious compartment with generous legroom, wide pedals, and a vibration-reducing floor mat keeps comfort high. Hydraulic controls are in the natural reach zone, reducing strain, and optional fingertip controls put every function at the driver's fingertips.

Top-tilt steering preserves knee space, while low step height and an open footpath make frequent entry and exit easy. Standard suspension seating keeps operators comfortable and focused all shift long.



Spacious Operator Compartment

Comfort starts with space, and the RENEGADE delivers:

- Ample leg, knee, and foot room
- Wide pedals are easy to reach and operate
- Rubber floor mat reduces vibration and improves traction
- Generous seat and steering column clearance



**Hydraulic Controls That Work With You
Standard Hood-Mounted Levers**

- Located directly beside the seat in the natural "reach zone"
- Short reach = less back strain and fatigue
- Far more ergonomic than competitor dash-mounted controls



Service Truck Through Smart Dash

Lots of trouble shooting can be done through the dash reducing the need to open the service hatch.

3 Power Modes

ECONOMY:	Lowest Energy Use
STANDARD:	Middle Performance
POWER:	Maximum Performance

FEATURE
09

INTELLIGENCE AT YOUR
FINGERTIPS

The 5.2" full-color LCD Smart Dash puts vital information front and center, performance modes, diagnostics, battery status, and safety alerts are all at a glance. Select from Economy, Standard, or Power mode to match your workload.

*Safety features are designed to assist operators but do not replace safe operating practices or OSHA training requirements.

FEATURE
10

CUSTOMIZE YOUR RENEGADE

Choose from safety lighting, mirrors, cab enclosures, fork positioners, custom carriage widths, and tire configurations to match your exact needs. USB charging ports, storage trays, and ergonomic controls make every shift more productive.



Confidence Comes Standard

Layered safety systems work in the background so operators can focus on the job. The electric brake automatically engages when the truck stops, is powered down, or the operator leaves the seat. The optional Vertical Mast System levels forks automatically, reducing pallet damage and increasing productivity.



Built Strong. Engineered Smart.

The RENEGADE's patented Nested I-Beam Mast resists twisting and deflection for rock-solid lifts, while slim I-beams and a low-profile cowl maximize forward visibility. Key components are sealed for dust and water protection, ensuring reliable performance indoors and out.



RENEGADE

Electric power. IC performance. Lower costs.
It's not just electric. It's electrifying.

S25-35XE SPEC SHEET

SPECIFICATIONS				CLARK		CLARK		CLARK	
1.1	Manufacturer (Abbreviation)			CLARK		CLARK		CLARK	
1.2.1	Manufacturer's designation			S25XE		S30XE		S35XE	
1.3	Drive unit Diesel, L.P. Gas			Elec-80V		Elec-80V		Elec-80V	
1.4	Operator type stand on / driver seated			Driver Seated		Driver Seated		Driver Seated	
1.5	Load capacity / rated load	Q	lbs (kg)	5000-2500		6000-3000		7000-3500	
1.6	Load centre distance	c	in (mm)	19.7-500		19.7-500		19.7-500	
1.8	Load centre distance, centre of drive axle to fork face	x	in (mm)	18.3-465		18.7-475		19.5-495	
1.9	Wheelbase	y	in (mm)	65.0-1650		66.9-1700		66.9-1700	
2.1	Service weight		lbs (kg)	65.0-3981		9676-4388		10558-4788	
2.2	Axle loading, laden front / rear		lbs (kg)	12593-5711	1698-770	14542-6595	1749-793	16302-7393	1973-695
2.3	Axle loading, unladen front / rear		lbs (kg)	3854-1748	4924-2233	4134-1875	5541-2513	4066-1844	6492-2944
3.1	Tyre type, P = pneumatic, SE = superelastic 1)			SE		SE		SE	
3.2	Tyre size, front			7.0-12		28x9-15		250-15	
3.3	Tyre size, rear			6.0-9		6.5-10		6.5-10	
3.5	Wheels, number front/rear (x = drive wheels)			2x/2		2x/2		2x/2	
3.6	Tread, front (wide/dual)	b10	in (mm)	39.2-995		39.5-1003		41.3-1049	
3.7	Tread, rear	b11	in (mm)	38.2-970		38.2-970		38.2-970	
4.1	Tilt of upright/fork carriage, back / forward		deg.	10/8		10/8		10/8	
4.2	Height, upright lowered	h1	in (mm)	85.2-2165		85.8-2180		86.6-2200	
4.3	Freelift	h2	in (mm)	4.3-110		4.3-110		4.5-115	
4.4	Lift height 2)	h3	in (mm)	129.9-3300		129.9-3300		124.6-3165	
4.5	Height, upright extended 4)	h4	in (mm)	154.5-3924		156.2-3967		154.1-3913	
4.7	Height overheadguard Std	h6	in (mm)	85.2-		85.8-2180		86.6-2200	
4.7.1	Height overheadguard (cab with audio antenna)	h6	in (mm)	86.4-2165		86.4-2193.5		87.1-2213.5	
4.7.2	Height overheadguard (cab with air-conditioner condenser)	h6	in (mm)	85.9-2181.5		86.5-2196.5		87.3-2216.5	
4.7.3	Height overheadguard (reduced OHG for container)	h6	in (mm)	82.0-2083		82.6-2098		83.4-2118	
4.8	Seat height	h7	in (mm)	45.6-1157		46.1-1172		46.1-1172	
4.12	Coupling height	h10	in (mm)	16.1-410		16.7-425		16.7-425	
4.19	Overall length	l1	in (mm)	142.2-3612		146.7-3727		154.3-3920	
4.20	Length to face of forks	l2	in (mm)	103.9-2640		109.1-2770		112.2-2850	
4.21	Width, Tires (wide/dual)	b1	in (mm)	46.9-1190		48.2-1225		50.3-1278	
4.21.1	Width, Frame outside	b1	in (mm)	46.9-1190		46.9-1190		49.5-1258	
4.22	Fork dimensions	s • e • l	in (mm)	1.75 (45) X 4 (100) X 42 (1070)		1.75 (45) X 4.8 (122) X 42 (1070)		2 (50) X 5 (125) X 42 (1070)	
4.23	Fork carriage DIN 15173, A, B			CLASS II		CLASS III		CLASS III	
4.24	Fork carriage width	b3	in (mm)	41.0		41-1041		45.1-1145	
4.31	Ground clearance laden, below mast	m1	in (mm)	5.3		5.9-150		6.7-170	
4.32	Ground clearance centre of wheelbase	m2	in (mm)	6.1		6.7-170		6.7-170	
4.33	Aisle width for pallets 1000 x 1200 crossways	Ast	in (mm)	154.9		157.3-3995		159.6-4055	
4.34	Aisle width for pallets 800 x 1200 lengthways	Ast	in (mm)	162.8		165.2-4195		167.5-4255	
4.35	Turning radius (truck)	Wa	in (mm)	89.4		91.7-2330		94.1-2390	
4.35.1	Turning radius (rear tire)	Wa'	in (mm)	82.2		84.1-2135		84.1-2135	
4.36	Internal turning radius	b13	in (mm)	29.2		29.6-751		29.6-751	
5.1	Travel speed laden/unladen		mph (km/h)	11.2-18	11.2-18	11.2-18	11.2-18	11.2-18	11.2-18
5.2	Lift speed laden/unladen		fpm (m/s)	80.7-0.42	106.3-0.54	77.3-0.39	97-0.49	69.5-0.35	81.1-0.41
5.3	Lowering speed laden/unladen		fpm (m/s)	108.2-0.55	98.4-0.5	108.9-0.55	97.6-0.49	92.5-0.47	84.6-0.43
5.5	Drawbar pull laden		lbf (kgf)						
5.6	Max. drawbar pull laden/unladen		lbf (kgf)	4535-2057	2456-1114	4361-1978	2734-1240	4398-1995	1731-785
5.7	Gradeability laden		%						
5.8	Max. gradeability laden/unladen		%	33.2	27.3	25.3	24.4	25.2	17.5
5.9	Acceleration time laden/unladen (0 - 15 m)		s						
5.10	Service brake								
6.1	Drive motor rating (S2 60min)		kW	17.2		17.2		17.2	
6.2	Lift motor rating (S3 15%)		kW	19.1		19.1		19.1	
6.3	Battery acc. to DIN43531/35/36 A,B,C,no			LFP		LFP		LFP	
6.4	Battery voltage, nominal capacity(Option)		AH/Shr	410		410		410	
6.5	Battery weight, min		lbs (kg)	688-312		688-312		688-312	
6.6	Energy consumption acc. to VDI cycle		kWh/h						
-	Diameter of drive motor		in (mm)	11.0-280		11-280		11-280	
-	Diameter of hydraulic motor		in (mm)	7.9-200		7.9-200		7.9-200	
8.1	Type of control			Inverter / AC		Inverter / AC		Inverter / AC	
8.2	Operating pressure for attachments		bar	Adjustable		Adjustable		Adjustable	
8.3	Oil volume for attachments		l/min	-		-		-	
8.4	Sound level, driver's ear to DIN 12053 3)		dB (A)	68.5		68.5		73	
8.5	Towing coupling, class/type DIN								

DIMENSIONS

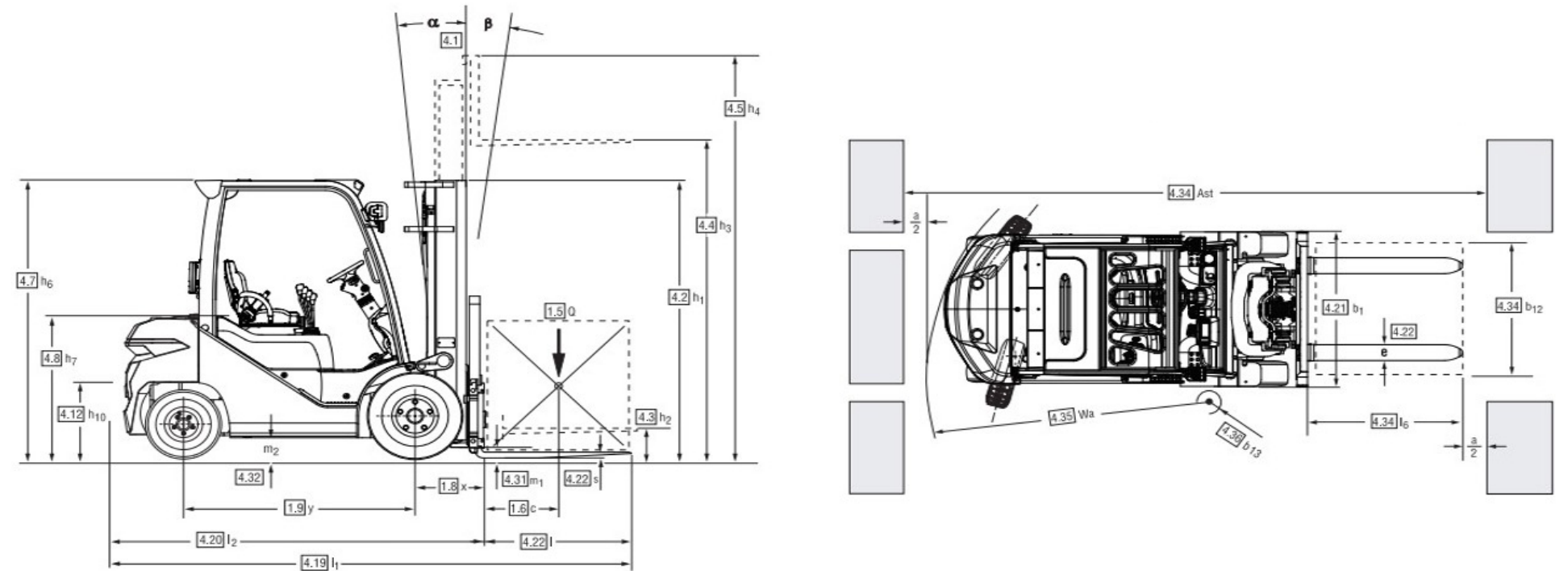

ABOUT CLARK

With over one million CLARK lift trucks sold around the world, each is a testament to the CLARK time-tested process of designing durable trucks with precise features that meet or exceed the material handling needs of our customers. Our full range of highly dependable products – from pallet jacks and electric narrow aisle order pickers to our 18,000lb capacity lift trucks - assure end-users that CLARK has the solutions for their day-to-day demands.

These customer-focused solutions are built from numerous industry innovations – from the nested I-Beam to a self-activating parking brake to new on-board diagnostics – and these all began the same way: with customers' needs foremost in mind. By focusing on how we can improve our customers' material handling processes, and combining that with award-winning dealers and parts support, CLARK ensures our customers a lift truck that is designed to be the right solution for their individual needs.

To Find Your Nearest Authorized CLARK Dealer, Visit Our Website

www.clarkmhc.com



CLARK MATERIAL HANDLING COMPANY

Global Headquarters
101 Lakeside Parkway • Flower Mound, TX 75028
1-859-422-6400 • www.clarkmhc.com