

# HIGHLIGHTS

## WHAT'S NEW?

- High Visibility 3.5" Interactive Dash Display
- Password Protected Access to Advanced Truck Settings
- Three Performance Modes: Economy, Standard, and Power
- Dash Integrates with Optional Equipment Including Load Weight Indicator, Seat Belt Interlock
- Performance Enhancement Package (PEP)
- Advanced Zapi Controllers
- Improved Operator Ergonomics
- 7,000 lb Capacity Offering
- S-SERIES Styling
- Rear Hinging Hood
- Turtle Mode Feature

## PERFORMANCE ENHANCEMENT PACKAGE (PEP)

The CLARK Performance Enhancement Package Features an Integrated Cutback Switch Which Provides Several Safety and Performance Benefits Including:

- Faster Travel Tilt Speeds and Aux Functions when Forks are Low for Increased Performance
- Slower Travel Tilt Speeds When Forks Are Raised for Improved Operator Control with Heavy Load

The PEP Applies to TSU, Quad, and 5 Stage Uprights

## LITHIUM-ION BATTERY

The CLARK Lithium-Ion Battery in the SEC20-35, Offered as an Optional Feature, Increases ROI, Decreases Downtime, and Retains Higher Sustained Power with No Voltage Drop-Off During Operation. Additional Features of the Lithium-Ion Battery Include:

- Virtually Maintenance-Free, with No Watering or Battery Swapping Required
- Provides a Safer Working Environment with No Acid to Leak
- Longer Battery Life, Requiring Fewer Replacements



## CLARK: The Innovative and Durable Solution

The design, development, and manufacturing capabilities of CLARK, in combination with an unparalleled focus on customer support, a drive to understand fully each customer's needs in order to then supply the right solution, reflect the key essence of what is CLARK.

With over one million CLARK lift trucks sold around the world, each is a testament to the CLARK time-tested process of designing durable trucks with precise features that meet, if not exceed, the material handling needs of our customers. Our full range of dependable products – from pallet jacks to electric narrow aisle order selectors and up to our big 18,000lb capacity lift trucks – assures end-users CLARK has the solutions for their day-to-day needs.



These solutions built from industry innovations, from the nested I-Beam to a self-activating parking brake to new on-board diagnostics, began the same way: with the needs of our customers foremost in mind. By focusing on how we can improve our customers' material handling processes, we can assure our customers a lift truck designed to be the right solution for their needs.

When you bring it all together – an extensive research and development process, state-of-the-art manufacturing capabilities, and a superior dealership network – you have a company dedicated to delivering leading edge products for both today and far into the future. More reasons why CLARK is Built to Last®.



CLARK S-SERIES products are designed from the ground up to be SMART, STRONG, and SAFE. The SEC20-35 brings all the power you need to keep your operation moving, without all of the harmful emissions. With excellent operator ergonomics, an advanced SMART dash that keeps operators informed, and a design that is *Built to Last*®, the SEC20-35 represents the next generation of electric lift trucks.

### SMART

The SEC20-35 integrates SMART features including:

- High-resolution 3.5" LCD Interactive Dash
- Zapi ACE3 Controllers for Advanced Control and Communication
- On-Board Diagnostics thru Display Screen
- Selectable Performance Modes

### STRONG

The SEC20-35 builds on the CLARK *Built to Last*® commitment, with STRONG features

Including:

- Increased Capacity to 7,000 lbs. Several Key Components Designed to Withstand Full Capacity, Adding Durability to all Models.
- Thick, Durable Front Fenders with Integrated Tie-Down Areas for Secure Transport
- Rear-Hinging Steel Hood Provides Durability and Ease of Service
- Steel Sump Tank Dissipates Heat Faster, Prolonging Oil Life

### SAFE

CLARK products are rooted in safety, and the addition to the S-SERIES continues that tradition with excellent SAFE features including:

- Dampening Block Stability (DBS) Offers Increased Resistance to Steer Axle Articulation Increasing Stability
- Cutback Switch on Mast Improves Control Via Performance Enhancement Package (PEP)
- Standard LED Lights
- Low Noise Pump Reduces Decibel Level 22%
- Turtle Mode Feature Restricts Drive Speed for Enhanced Safety
- Optional Self-Activating Parking Brake
- Additional Optional Safety Equipment Includes Load Weight Indicator, Seatbelt Interlock, and More!



"CLARK, TOTALIFT, Powrworker, PartsPRO Plus, and Built to Last are registered in the U.S Patent and Trademark office. The "Hot Yellow Green" also known as "CLARK Green" is a trademark registered in the U.S Patent and Trademark office."



## SEC25

Max Load Capacity  
4000/5000/6000/6500/7000 lbs.  
(1814/2268/2722/2948/3175 kg)



20/25/30/32/35



CLARK MATERIAL HANDLING COMPANY  
North American Headquarters  
700 Enterprise Drive • Lexington, KY 40510  
866-252-5275 • [www.clarkmhc.com](http://www.clarkmhc.com)

SEC20-35  
59-894-2030 Printed in USA OTP1022500  
© 2022 CLARK Material Handling Company

**SMART · STRONG · SAFE**

### Advanced Ergonomics



- Optimized Floorboard Angle and Redesigned Operator Compartment For Enhanced Ergonomics
- Ergonomic Hood Mounted Levers
- Cowl-Mounted 3.5" LCD Dash Display Allows for Greater Visibility
- Light Switches on Steering Column for Ease of Operation
- Rear Hinging Hood for Ease of Service Access
- Small Steering Wheel (11.2") and Standard Spinner Knob Reduces Operator Fatigue
- Accelerator and Brake Pedals Positioned for Smooth Foot Transition
- Regen Braking Puts Energy into the Battery and Reduces Wear on the Brakes

### Solid and Versatile



- Field-Tested and Strength-Proven Drive Unit, Steer Axle, and Upright
- Several Key Components Designed for 7,000 lb Unit for Increased Reliability
- Welded Heavy Gauge Frame Provides Lasting Durability
- CLARK Nested I-Beam Mast Designed for Stability and Longevity



### Advanced Componentry



- High Visibility 3.5" Interactive Dash Display Allows Operators to Remain in Control
- Password Protected Access to Truck Settings
- Multiple Performance Modes: Economy, Standard, and Power
- Turtle Mode Feature
- Dash Integrates with Optional Equipment Including Load Weight Indicator, Seat Belt Interlock, and More

### Low Cost of Ownership



- Optional Self-Activating Parking Brake (SAPB)
- Steel Sump Tank Dissipates Heat Faster to Minimize Hydraulic Oil Temperature
- Optional Lithium-Ion Battery Requires Less Maintenance and Offers Improved ROI

**SMART ■ STRONG ■ SAFE**

## SEC20-35 Specifications

General Information			CLARK	CLARK	CLARK	CLARK	CLARK	
			SEC20	SEC25	SEC30	SEC32	SEC35	
1	Manufacturer		CLARK	CLARK	CLARK	CLARK	CLARK	
2	Model	Manufacturer's Designation	SEC20	SEC25	SEC30	SEC32	SEC35	
3	Load Capacity	lbs(kg)	4000 (1814)	5000 (2268)	6000 (2722)	6500 (2948)	7000 (3175)	
4	Load Center distance	Fork Face to Load CG	in(mm)	24 (610)	24 (610)	24 (610)	24 (610)	
5	Power Unit		Elec-36V/48V	Elec-36V/48V	Elec-36V/48V	Elec-36V/48V	Elec-48V	
6	Operator type		Rider-seated	Rider-seated	Rider-seated	Rider-seated	Rider-seated	
7	Tire type	P=pneumatic, SE=superelastic, C=cushion	C	C	C	C	C	
8	Upright1	Maximum Lift Height, Full Capacity	in(mm)	189 (4800)	189 (4800)	189 (4800)	189 (4800)	
9		Lift height (Preferred Upright)2	in(mm)	189 (4800)	189 (4800)	189 (4800)	189 (4800)	
10		Freelift (Preferred Upright)2	in(mm)	61 (1549)	61 (1549)	61 (1549)	59 (1499)	
11	Upright Tilt	Back/Forward	deg.	5 / 6	5 / 6	5 / 6	5 / 6	
12	Fork	Std. Fork Size (T x W x L)	in(mm)	1.75(44) x 4(102) x 42(1067)	1.75(44) x 4(102) x 42(1067)	1.75(44) x 5(127) x 42(1067)	2(51) x 5(127) x 42(1067)	2(51) x 5(127) x 42(1067)
13	Carriage	Width of Carriage5 / Type	in(mm)	37(940) / Class II STD	37(940) / Class II STD	41(1041) / Class III STD	41(1041) / Class III STD	45(1143) / Class III STD
14	Overall Dimensions	Length to face of forks	in(mm)	86.3 (2192)	88.8 (2255)	90.3 (2294)	94.2 (2393)	96.0 (2438)
15		Width (OAW - Across Drive Tires)4	in(mm)	41.9 (1064)	43.9 (1115)	43.9 (1115)	45.4 (1153)	45.4 (1153)
16		Width (Across Frame)	in(mm)	41.8 (1062)	41.8 (1062)	41.8 (1062)	41.8 (1062)	41.8 (1062)
17		Height, upright lowered2	in(mm)	83.5 (2121)	83.5 (2121)	83.5 (2121)	83.5 (2121)	83.5 (2121)
18		Height upright extended (with load backrest)2	in(mm)	237 (6020)	237 (6020)	237 (6020)	237 (6020)	237 (6020)
19		Height Overhead Guard	in(mm)	88 (2235)	88 (2235)	88 (2235)	88 (2235)	88.5 (2248)
20	Step Height	Ground to Top of Step	in(mm)	18.3 (465)	18.3 (465)	18.3 (465)	18.3 (465)	18.8 (478)
21	Turning radius		in(mm)	72.7 (1847)	75.1 (1908)	76.7 (1948)	81.5 (2070)	83.25 (2115)
22	Load Center distance	Center of Drive Axle to Fork Face2	in(mm)	17.5 (445)	17.5 (445)	17.5 (445)	17.75 (451)	17.75 (451)
23	Right Angle Stack:	Add Load Length and Clearance2	in(mm)	90.2 (2291)	92.6 (2353)	94.2 (2393)	99.2 (2520)	101.0 (2566)
27	Stability	According to ANSI	Yes	Yes	Yes	Yes	Yes	
28	Travel speed (48V)	Loaded / Unloaded	mph (kph)	11.3 (18.2) / 11.8 (19.0)	11.0 (17.7) / 11.5 (18.5)	10.0 (16.1) / 10.8 (17.4)	9.7 (15.6) / 10.6 (17.1)	9.3 (15.0) / 10.6 (17.1)
29	Travel speed (36V)	Loaded / Unloaded	mph(kph)	9.1 (14.6) / 9.5 (15.3)	8.9 (14.3) / 9.3 (15.0)	8.5 (13.7) / 8.9 (14.3)	8.2 (13.2) / 8.7 (14.0)	NA / NA
30	Lift speed (48V)	Loaded / Unloaded	fpm(mps)	98.4 (0.50) / 117.6 (0.60)	90.5 (0.46) / 117.6 (0.60)	80.2 (0.41) / 101.2 (0.51)	75.8 (0.38) / 101.2 (0.51)	72.2 (0.37) / 101.2 (0.51)
31	Lowering speed(48V)	Loaded / Unloaded	fpm(mps)	98.0 (0.50) / 90.7 (0.46)	98.9 (0.50) / 90.7 (0.46)	100.2 (0.51) / 90.7 (0.46)	101.9 (0.52) / 90.7 (0.46)	102.5 (0.52) / 90.7 (0.46)
32	Lift speed (36V)	Loaded / Unloaded	fpm(mps)	65.6 (0.33) / 102.5 (0.52)	59.9 (0.30) / 102.5 (0.52)	58.8 (0.30) / 92.2 (0.47)	57.5 (0.29) / 92.9 (0.47)	NA / NA
33	Lowering speed (36V)	Loaded / Unloaded	fpm(mps)	98.0 (0.50) / 90.7 (0.46)	98.9 (0.50) / 90.7 (0.46)	100.2 (0.51) / 90.7 (0.46)	101.9 (0.52) / 90.7 (0.46)	NA / NA
34	Grade Clearance	%	51.0	40.4	40.4	40.4	40.4	
36	Service weight - with minimum battery weight	lbs(kg)	9519 (4318)	10578 (4798)	10936 (4960)	11635 (5278)	12240 (5552)	
37	Axle loading, loaded front / rear3	lbs(kg)	11361 (5153) / 2158 (979)	13332 (6047) / 2246 (1019)	15016 (6811) / 1920 (871)	15891 (7208) / 2244 (1018)	16873 (7653) / 2367 (1074)	
38	Axle loading, unloaded front / rear3	lbs(kg)	4429 (2009) / 5290 (2400)	4417 (2004) / 6161 (2795)	4318 (1959) / 6618 (3002)	4630 (2100) / 7005 (3177)	4746 (2153) / 7494 (3399)	
39	Tires	Number, Front/Rear (X=drive wheels)	2X / 2	2X / 2	2X / 2	2X / 2	2X / 2	
40		Tire size, front	21x7x15 (533x178x381)	21x8x15 (533x203x381)	21x8x15 (533x203x381)	21x9x15 (533x229x381)	22x9x16 (559x229x406)	
41		Tire size, rear	16x6x10.5 (406x152x267)	16x6x10.5 (406x152x267)	16x6x10.5 (406x152x267)	16x6x10.5 (406x152x267)	16x7x10.5 (406x178x267)	
42	Wheelbase	in(mm)	53 (1346)	53 (1346)	53 (1346)	57 (1448)	57 (1448)	
43	Track	Tread, front	in(mm)	34.8(894)	35.8 (909)	35.8 (909)	36.5 (927)	36.5 (927)
44		Tread, rear	in(mm)	34.2 (869)	34.2 (869)	34.2 (869)	34.2 (869)	35.2 (894)
45	Ground clearance	Minimum, unloaded	in(mm)	2.8 (71)	2.8 (71)	2.8 (71)	2.8 (71)	2.8 (71)
46		Center of Wheelbase	in(mm)	4.5 (114)	4.5 (114)	4.5 (114)	4.5 (114)	4.5 (114)
47	Service brake	Type	Drum and Shoe	Drum and Shoe	Drum and Shoe	Drum and Shoe	Drum and Shoe	
48	Parking brake	Type	Pedal Actuated	Pedal Actuated	Pedal Actuated	Pedal Actuated	Pedal Actuated	
49	Steering	Type	Hydrostatic	Hydrostatic	Hydrostatic	Hydrostatic	Hydrostatic	

		Manufacturer's Designation		SEC20	SEC25	SEC30	SEC32	SEC35	
Drive Line	51	Battery compartment dimensions (WxLxH)7	Standard Compartment	in(mm)	39.25(997) x 30.5(775) x 23.4(594)	39.25(997) x 30.5(775) x 23.4(594)	39.25(997) x 30.5(775) x 23.4(594)	39.25(997) x 34.5(876) x 23.4(594)	39.25(997) x 34.5(876) x 23.4(594)
	52		Option 1	in(mm)	39.25(997) x 34.5(876) x 23.4(594)	39.25(997) x 34.5(876) x 23.4(594)	39.25(997) x 34.5(876) x 23.4(594)		
	53		Max Capacity (6 Hour Rating)	Kwh	41.8	41.8	41.8	48.6	48.6
	54		Battery weight (Min/Max)	lbs(Kg)	2600 (1179) / 3200 (1451)	2600 (1179) / 3200 (1451)	2600 (1179) / 3200 (1451)	3100 (1406) / 3600 (1633)	3100 (1406) / 3600 (1633)
	55	Motors, Controls	Diameter of drive motor	in(mm)	10.6 (269)	10.6 (269)	10.6 (269)	10.6 (269)	10.6 (269)
56		Diameter of hydraulic motor	in(mm)	7.9 (200)	7.9 (200)	7.9 (200)	7.9 (200)	7.9 (200)	
57		Drive motor control		Inverter	Inverter	Inverter	Inverter	Inverter	
58		Hydraulic motor control		Inverter	Inverter	Inverter	Inverter	Inverter	
Misc.	59	Operating pressure for attachments		psi	2987	2987	2987	3335	3385
	60	Oil volume for attachments AUX1 / AUX2 max8		gpm (lpm)	18.5 (70)	18.5 (70)	18.5 (70)	18.5 (70)	18.5 (70)

1. See upright table for other available uprights.
2. Dimensions are for 189" TSU uprights.
3. Specifications are given with preferred 189" TSU upright and minimum battery weight.
4. OAW with wide drive tires is 48.8in. w/7"; 50.8in w/8"; 52.8in w/9" drive wheels for models with all quad uprights, and with triple stage uprights above 236in.
5. 36in. max fork spread w/37in. carriage. 40in. max fork spread w/41in. carriage.
6. Performance may vary +5% and -10% due to motor and system efficiency tolerance. The performance shown represents nominal values which may be obtained under typical operating conditions of a standard machine.
7. Recommended battery should be 12" - 3/8" less than listed dimensions.
8. UL certification is for a maximum Ah (6hr) rating of 1400Ah at 36V and 1000Ah at 48V with lead-acid battery.
9. For EHL Applications oil volume for attachment AUX1/AUX2 max 10.6 gpm/40 lpm.

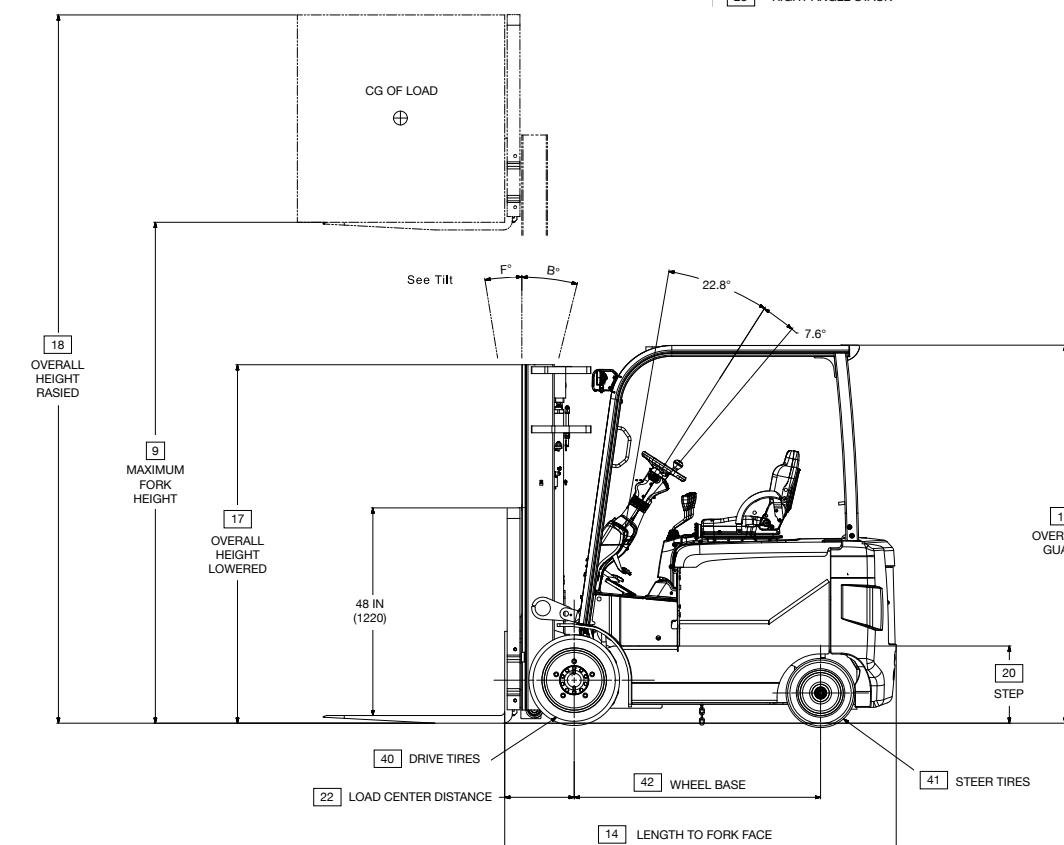
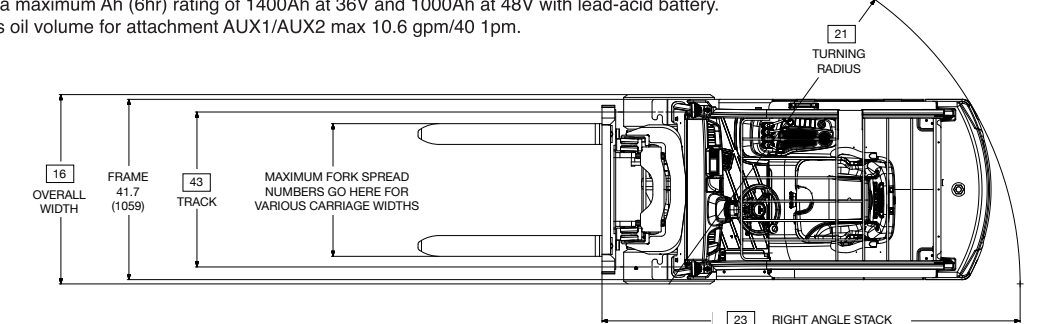

Above specs correspond with the SEC20-35 Specifications on the page to the left.