

KOMATSU®

BX50

LP & Dual Fuel Engines

CUSHION & PNEUMATIC FORKLIFTS

BX50 SERIES



Photos may include optional equipment.

RATED CAPACITY

4,000 - 6,500 lb
1,815 - 2,950 kg

LOAD CENTER

24 in.
600 mm

WALK-AROUND

BX50 SERIES



FG25T-16

Photos may include optional equipment.

RATED CAPACITY @ LOAD CENTER

<u>Pneumatic</u>	<u>Cushion</u>	
FG20T-16	FG20ST-16	4,000 lb (1,815 kg) @ 24 in. (600mm)
FG25T-16	FG25ST-16	5,000 lb (2,270 kg) @ 24 in. (600mm)
FG25HT-16	FG25SHT-16	5,000 lb (2,270 kg) @ 24 in. (600mm)
FG30HT-16	FG30SHT-16	6,000 lb (2,725 kg) @ 24 in. (600mm)
FG32HT-16	FG32SHT-16	6,500 lb (2,950 kg) @ 24 in. (600mm)

Comfort & Efficiency

- Komatsu's dual floating structure limits vibration and increases operator comfort
- Komatsu's Komfort Zone™ is built to fight vibration while providing superior durability
- The BX50 console has a full range of displays to keep the operator informed
- A Fully Hydrostatic Power Steering system allows for easy steering and less operator fatigue
- Komatsu's EZview® mast offers unrestricted views of the fork tips and surroundings

Durability & Reliability

- 90+ years of Komatsu design & manufacturing experience continues to deliver exceptional performance and reliability
- Extended service intervals, simplified maintenance and rapid service access may help reduce downtime and operating costs
- The BX50 was awarded EquipmentWatch's 2017 Highest Retained Value Award for forklifts

Ecology & Economy

- Fuel economy is achieved through use of an electronic engine control module along with Komatsu's advanced hydraulic system
- Komatsu's optional Telematics Lite makes your forklift smarter and your rental fleet more efficient
- Clean air performance is achieved through advanced engine designs & technologies to reduce environmental impact



FG20ST-16



FG25ST-16/FG25SHT-16



FG30SHT-16



FG32SHT-16



FG20T-16



FG25T-16/FG25HT-16



FG30HT-16



FG32HT-16

COMFORT & EFFICIENCY

KOMFORT ZONE™

Komatsu's Komfort Zone™ Cares For Your Operators

At Komatsu Forklift, we know operator comfort is critical to reducing fatigue and increasing productivity. We take pride in providing total operator comfort with the Komatsu Komfort Zone™: a dual floating structure that protects operators through advanced ergonomic design. The Komfort Zone™ reduces the effects of engine vibration, noise and heat.

Komfort Zone™ Vibration Reduction

The Komfort Zone™ reduces the effects of vibration in several ways. First, vibration dampening mounts separate the engine and transmission from the forklift's frame. Next, additional suspension mounts isolate the operator compartment from the frame. Vibration transmitted from the differential is also reduced by an advanced drive train design.

Komfort Zone™ Superior Durability

Besides operator comfort, the BX50 also provides superior durability that reflects the influence of Komatsu's construction machine heritage. The heavy gauge steel frame, front axle and heavy duty front fender connect to deliver high strength, which is critical for high lifting heights and heavy loads. Operators will appreciate the BX50's reliable day-after-day capabilities.

Tall Or Short, Operators Like the BX50

Tall, average, or short, your operators will find the BX50 comfortable. Start with extra headroom in the overhead guard. Then add foot room and floor space with dash suspended pedals and tilt cylinders tucked out of the way under the floor. The BX50 comfortably accommodates operators of all sizes.



BX50 SERIES



Easy Steering Even At Rest

Even when the BX50 is standing still, its Fully Hydrostatic Power Steering (FHPS) system allows easy steering. The FHPS system also reduces operator fatigue by eliminating kickback. The operator's feel and control are improved by a small diameter steering wheel that allows easier one-handed steering.

Komatsu's "Komfort S" Full Suspension Seat

The Komatsu "Komfort S" Full Suspension Seat further increases the comfort of the BX50 in conjunction with the dual floating structure of the machine. The seat also comes with:

- Adjustable Backrest
- Orange Seat Belt
- Low Profile Hip Restraint
- Wide, Spacious Seat Cushion
- Front to Back Adjustment
- Easy Access Seat Belt
- Easy On / Easy Off



EZview[®] Mast

With the excellent visibility window of the EZview[®] mast, the BX50 operator has an unrestricted view of the fork tips and surroundings. Towards the front, the EZview[®] mast, console and a low-profile dash display give maximum visibility. To the rear, the upper corners of the counterweight are angled for clear sightlines in reverse.



Full Instrumentation

The BX50 console keeps the operator informed with displays including:

- Neutral Indicator
- Engine Oil Pressure Gauge
- Low Battery/Alternator
- Fuel Gauge
- Hour Meter
- KOPS (Komatsu Operator Presence System) Plus
- Hydraulic Lock Indicator
- Check Engine Indicator
- Maintenance Error Code Display
- Engine Temperature Gauge

Operators Stay Cool

Hot engine air doesn't bother operators when the BX50 travels in reverse. Angled exit ports for engine air and low mounted exhaust vents direct air away from the operator compartment and away from the floor. Operators stay cool with less dust and dirt stirred into the air.

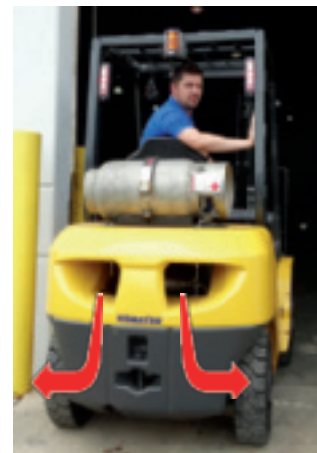

DURABILITY & RELIABILITY

EXPERTISE AND EXPERIENCE ARE BUILT IN

90+ Years Of Experience Brings You High Reliability

With the Komatsu BX50, we rely on our 90+ years of experience to deliver exceptional performance and reliability. You can trust Komatsu's advanced engineering to deliver long life in tough applications.

- Sophisticated airflow design helps control the BX50's underhood cooling. Fan shroud contours increase engine compartment air flow from a high velocity, low noise ten bladed fan. Air moves straight through the radiator and across the exhaust system. The radiator housing controls air movement to keep the hood cool and prevent hot air from circulating back into the engine compartment.
- Engine overheating protection automatically limits BX50 engine speed if coolant temperature rises. A two-stage temperature sensing system will shut the engine down to protect it if coolant temperatures exceed safe operating limits.

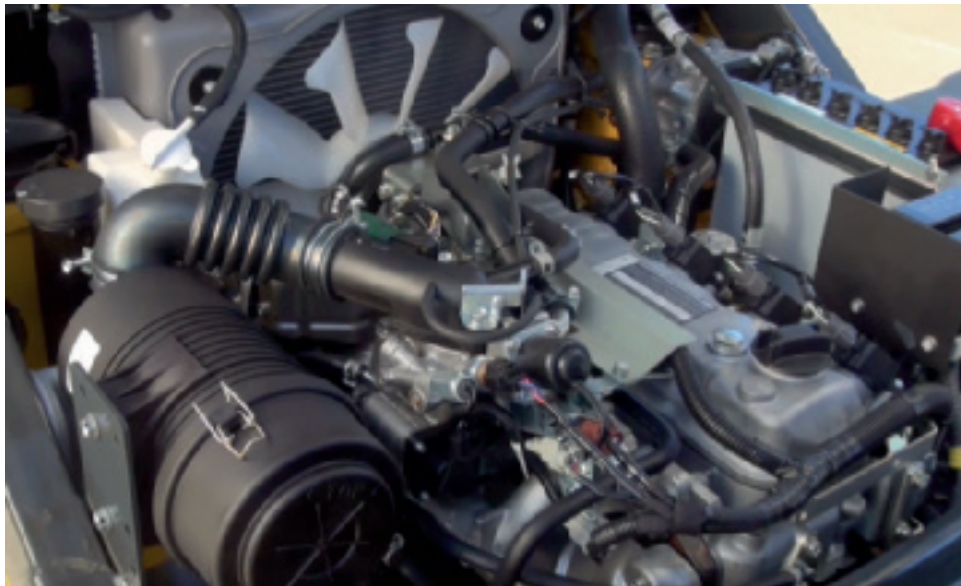

Low Maintenance Steering & Wiring

The BX50 steer axle is controlled by a double acting, double ended cylinder that eliminates drag links and tie rods that wear and require maintenance. Added durability comes from high capacity kingpin needle bearings with heavy duty seals.

The BX50 dashboard wiring harness takes wet environments in stride. The engine wiring and steering control system all use the latest generation of waterproof connections for improved reliability.

Diagnostic System Speeds Troubleshooting

Inspection and maintenance operations are simplified by a single, conveniently located fuse box and wiring harness. Reliable operation in harsh environments is assured by waterproof connectors in critical areas. If trouble does occur, the BX50's diagnostic system makes troubleshooting with a handheld diagnostic tool quick and easy.

Simplified Maintenance Improves Your Bottom Line

BX50 extended service intervals, simplified maintenance and rapid service access may help reduce downtime and operating costs. Expect reduced BX50 life cycle costs to improve your bottom line.

Rapid Access For Daily Checks

The BX50 saves minutes with every daily check. Quickly check brake fluid by lifting a single cover by the steering wheel. Get rapid access to engine components with a durable, one-piece, lightweight steel engine cover and a lift out floorboard. The gas cylinder assisted engine cover easily opens with a single latch and a locking device holds the cover open.

Easy Maintenance Brakes Self-Adjust

BX50 drum and shoe brakes are self-adjusting, reliable and easy to maintain. Brake linings are designed for extended lining life and a healthier working environment. Extra thick brake drums improve heat resistance in severe duty applications.

KOPS Plus Protects Your Workplace

The BX50 features KOPS Plus to protect people and equipment if the operator leaves the seat. If the seat is vacant for more than three seconds, KOPS Plus automatically locks out all lift, lower, tilt and travel functions. The operator must return to the seat to unlock the system. A flashing yellow warning light alerts the operator when KOPS Plus is activated. In addition, the BX50 forks cannot be lowered with the key in the off position.

EquipmentWatch Highest Retained Value Award

The Komatsu BX50 Series forklift earned the honor of Highest Retained Value from EquipmentWatch in 2017. This award is a testament to the BX50's high product quality, high resale value and strong customer loyalty as measured against all forklift manufacturers.



ECOLOGY & ECONOMY

MAKE YOUR JOB SITE EASIER TO WORK AND BE PRODUCTIVE IN

The BX50 Series helps create a workplace that's easier to work and be productive in. Sound levels are lower with the BX50 because the drive train generates high operating torque at low engine speeds.

Engine emissions in gasoline and LPG engines are managed by our Engine Control Module (ECM) that produces exceptionally low emission levels because it more accurately regulates air-fuel ratios for optimum combustion. The result is the BX50 exceeds Tier II regulations for gasoline and LPG engine exhaust emissions set by the U.S. Environmental Protection Agency (EPA).



BX50 SERIES

Fuel Economy Built In With EZLift™ Hydraulics

Excellent fuel economy is achieved through a combination of electronic engine control technologies and an efficient optimized fuel injection system. These advanced technologies boost fuel economy with our LPG or flexible dual fuel (LPG/Gasoline) systems.

The BX50's fuel economy is further boosted by the EZlift™ hydraulic system, which uses a tandem pump to supply independent power for lifting and steering. The tandem pump eliminates the flow divider between the pump and control valve. EZlift™ hydraulics give you smooth lifting without revving up the engine, which reduces fuel consumption. It also keeps the engine from stalling when steering and lifting, produces less temperature buildup and delivers better control in tight areas.

Komatsu's Telematics Lite NEW

Komatsu's New Telematics Lite option for the BX50 includes the following features & benefits:

- GPS tracking
- Remote hour meter readings
- Maintenance reminders
- Online dashboard for fleet tracking and usage reports in real time
- Vital real-time information allows for timely fleet management
- Performing PM maintenance only when needed saves time and money



Telematics Lite helps make your forklift smarter and your rental fleet more efficient, giving you basic telematics at an affordable price.





Komatsu Engineering Standards

Reliability is another key component to reducing overall cost for our customers and with the BX50 model several changes and improvements were made to increase reliability. Some of those changes and improvements are:

- Addition of O-ring face seals on specific hydraulic connections
- Added waterproof connectors in the dashboard wiring harness, engine wiring harness, and steering control system
- Utilization of patterned gaskets with the hydraulic and fuel tanks to further eliminate the possibility of leaks
- Protected wiring
- Fully fused circuits
- Optimal protected horn location
- Protection for rear combo lights
- LED tail lamps

Komatsu's Drive Train Handles High Torque

The high torque delivered by the BX50's powerful GK21 and GK25 engines is channeled through a transmission designed and manufactured by Komatsu. This rugged drive train features an aluminum alloy transmission case for improved heat dissipation, a high capacity oil cooler for the torque converter and O-ring face seals to greatly reduce the possibility of leaks.

Komatsu's extensive experience with demanding construction machinery applications led to a highly reliable and highly dust resistant double seal universal joint design in the full floating BX50 drive train.

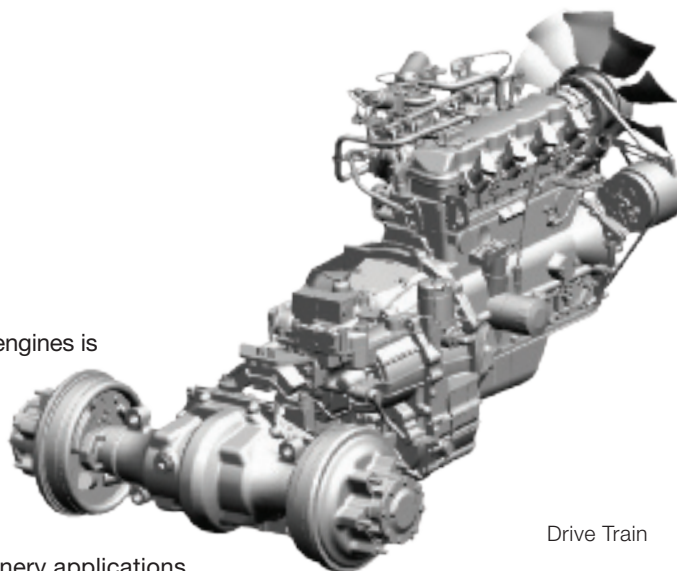

Drive Train

Versatility of the Komatsu BX50

Whether your application calls for an agile and maneuverable cushion tire model for indoors, or the flexibility and power of a pneumatic model for outdoors, the BX50 series is sure to meet your needs.

The BX50's superior performance can increase productivity, minimize operator fatigue, reduce operating costs and improve the working environment. Boost your bottom line now and put a BX50 to work in your application today.

TECHNICAL DATA

ENGINE – LPG / DUAL FUEL

- GK21 (2.1 liter) or GK25 (2.5 liter) LPG/Dual Fuel, 4-cylinder, electronically controlled industrial engines exceed EPA emissions standards. These low-RPM, high torque engines offer reduced maintenance requirements, exceptional emissions controls, fast acceleration, high performance, reliability, durability and enhanced serviceability through engineering excellence.
- All engines are equipped with 3-way catalytic converters and closed-loop exhaust systems
- All engines utilize an electronic control module that continuously monitors data on fuel pressure, accelerator throttle position, mass airflow sensor, and heated oxygen sensor – for improved fuel economy, smooth operation, reliable starting in cold weather and high performance throughout the operating range
- An electronic throttle governor protects the engine against over-rev damage
- Crankshaft and camshaft position sensors provide information to the electronic control module for optimum ignition and fuel injection timing
- Each cylinder has an individual ignition coil for precise control and reliability
- An engine coolant temperature sensor and controller protects the engine against damage due to high engine temperature by automatically limiting engine speed during high temperature operation. If the engine coolant temperature exceeds safe operation temperature, the engine will shut down. An illuminated indicator on the instrument console indicates high-temperature operation, and gives the operator warning of engine shutdown.
- Aluminum alloy cylinder heads have large intake and exhaust valves and a semi-hemispherical combustion chamber for more efficient fuel consumption
- The engine block is designed with five main bearings. All main and rod bearings are micro-grooved to improve lubrication and reduce wear.

FUEL SYSTEM

- LPG fuel system is standard and uses single-point, throttle body fuel injection. A removable 33 lb. or 43 lb. LPG fuel tank is available with stationary, fold-back or swing-out-and-down tank brackets.
- The optional Dual-Fuel system[†], has a fuel tank integral to the truck frame, an in-tank mounted gasoline fuel delivery pump, fuel level sensing unit, pressure regulator and filter with easy change-over at the flip of a switch

COOLING SYSTEM

- The high capacity aluminum radiator is designed with an efficient thermal transfer fin and integral oil cooler for the transmission torque converter
- System design allows easy access to the reservoir for checking the coolant level
- High volume cooling fan uses flexible plastic blades and shroud for maximum air volume and noise reduction

ELECTRICAL SYSTEM

- 12-volt electrical system
- 50A alternator with built-in IC regulator
- Key-lock, anti-restart ignition switch
- High-torque, low-amp starter motor with planetary gear reduction
- Waterproof electrical connector
- Service Support Tool connector for rapid system diagnostics
- Standard instrument package and operator conveniences include:
 - Electric fuel gauge, water temperature gauge and LCD hour meter
 - Indicator lights for Neutral/Return to Neutral, Low Oil Pressure, Low Battery/Alternator Output, Check Engine Warning, Hydraulic Lock (Operator Presence), and engine status codes

EZLIFT™ HYDRAULIC SYSTEM

- The fully filtered EZLIFT™ Hydraulic System features a powerful and efficient direct drive tandem gear pump assembly with separate pumps for load handling and steering, enabling faster lifting at engine idle speed for greater fuel economy and better hydraulic performance
- Large hydraulic fluid reservoir integral to the truck frame reduces heat buildup in the system
- The independent steering pump assures no power steering loss even when performing other hydraulic functions
- Load sensing valve in the hydraulic circuit reduces the flow of oil to the power steering system when steering wheel is idle
- 3-way control valve is standard with 4-way control valve optional

FRAME

- An all-welded frame assembly with heavy gauge steel and integral hydraulic and fuel tanks provide exceptional durability
- Welded front cross-member and bolted drive axle increases frame rigidity
- Loads are transferred directly from the mast to the drive axle and onto the floor without being transmitted through the frame, reducing frame stress
- Wide, open step area, with non-slip surface facilitates easy operator entry and exit to and from the operator compartment

DRIVE AXLE

- A heavy duty, cast steel drive axle housing supports the load and chassis without placing a load on the free-floating axle shafts
- A flange is mounted to the truck frame to improve load distribution and reduce frame flexing

TRANSMISSION

- Komatsu Torqflow single-speed, powershift automatic transmission is specifically designed for industrial applications
- An electrical shift lever mounted to the left side of the steering column gives the operator easy directional control without removing a hand from the steering wheel
- Optimized stall ratio for the torque converter provides high torque without sacrificing travel speed
- A modulating control valve absorbs initial pressure spikes during initial engagement and directional changes. This improves shifting capabilities and prolongs the life of the entire drive train.
- Transmission oil is double filtered by a 125-micron mesh on pickup and a 35-micron cartridge in the return line
- Transmission oil cooler is integral with the radiator
- Inching control and brake pedal combination allows the operator precise truck positioning with positive control

BRAKES

- Hydraulic brakes are self-energizing and self-adjusting
- Brake fluid reservoir is located under the console cover for fast, easy inspection and maintenance
- Heavy duty brake backing plate and thick brake drum provide reliable braking action with reduced heat
- Mechanical parking brake has a two-stage latching mechanism for positive engagement

STEER AXLE

- Fully Hydrostatic Power Steering is standard
- Independent power steering pump separates steering function from main hydraulics for smoother, more reliable action
- Heavy duty fabricated steer axle has double acting, double ended power steering cylinder with no drag links or tie rods
- Steering stops are machined into the steering cylinder to reduce stress impact on steering linkages
- Grease fittings on all linkages are accessible without lifting the truck

MAST, CARRIAGE, LOAD BACKREST AND FORKS

- High visibility EZview® mast assemblies are available in two-stage limited free lift; two-stage, three-stage and four-stage full free lift designs
- Sealed mast bearings reduce required maintenance
- Angle-mounted bearings and a shaped rail flange prevent excessive wear and friction, while maintaining correct side thrust clearance
- ITA Class II or Class III 6-roller carriages accept a variety of fork sizes and common load-handling attachments
- 48 inch high load backrest is standard for increased load control and operator protection
- Internal hose reeving is available for 3-way and 4-way auxiliary hydraulic functions

KOMFORT ZONE™ OPERATOR COMPARTMENT

- A unique dual floating structure floats the drive train and operator compartment on rubber cushions to greatly reduce vibration that can be transmitted through the frame and to the operator compartment
- The full floating Komfort Zone™ operator compartment isolates the operator from the floor surface and from engine vibrations for greater comfort and increased productivity
- Full suspension Komfort "S" vinyl seat with orange retractable seat belt, operator restraint system, backrest, operator weight and front to back adjustability (All models except FG20ST)
- Hydraulic control levers are positioned for optimal access and ease of use. International symbols on the contoured grips indicate the lever function.
- Tilt steering column has a small-diameter steering wheel and electronic instrumentation. Tilt is infinitely adjustable, with extended room between the engine cover and console for more operator space.
- Wide-open floorboard has suspended brake and inching pedals with ribbed rubber pads for comfort and safety. Integral accelerator mechanism has a transfer roller for smooth operation
- Full width rubber floor mat provides a large, non-slip surface and reduces noise, vibration and heat in the compartment
- Large, open steps with a traction surface and a large handgrip provide easy entry and exit for the operator
- Standard headlight/turn indicator control lever is mounted on the steering column for easy access
- Full width overhead guard provides excellent visibility for high stacking and meets ITSDF B56.1 requirements

SERVICEABILITY

- The engine and transmission can be easily accessed for daily inspection without the use of any tools
- Single piece, all steel engine cover and seat support is fully insulated to reduce noise and heat transfer to the Komfort Zone™
- Engine cover has a gas spring with an automatic locking device to assist in opening and preventing the cover from unexpectedly closing
- Easy access engine cover latch is recessed to prevent interference when entering and exiting the operator compartment
- Engine cover is contoured for easy access into the engine compartment for maintenance and service

COMPLIANCE, APPROVALS AND ENVIRONMENTAL CONCERNS

- Designed for maximum recycling at end of life, with special attention to materials and construction. Counterweight designed for breakup during recycling process. Transmission case is recyclable aluminum.
- Komatsu forklifts meet or exceed American National Standard Institute, ITSDF B56.1-Part III Safety Standards for Powered Industrial Trucks
- Classified by Underwriters Laboratories, Inc. for fire hazard only. Contact your dealer for application-specific requirements.
- Meets EPA emissions standards Tier II

[†] Available on Pneumatic models only

EQUIPMENT

STANDARD EQUIPMENT

- Low profile dash display: Fuel Gauge, Water Temperature Gauge and Hour Meter
- Indicator lights: Neutral/Return to Neutral, Low Oil Pressure, Low Battery/Alternator, Hydraulic Lock (Operator Presence), Check Engine Warning and Maintenance Error Code
- Drawbar Pin in Counterweight
- Electronic Ignition, Anti-Restart Ignition Switch
- Fully Hydrostatic Power Steering
- LED Tail/Stop/Rear Turn Lights
- High-Mount Air Intake
- Horn with Actuator on Center of Steering Wheel
- Three Piece Overhead Guard
- Three Function Hydraulic Control Valve
- Parking Brake with Double-Action Release
- Tilting Steering Column
- Large, Open Floor Space with Operator Compartment Suspended-Mount Pedals
- Transmission Torque Converter Oil Cooler
- Load Backrest
- Spacious Step Area, Large Entry Handgrip and Wide Open Floor Space allows easy entry/exit to the Komfort Zone
- Engine Protection System
- ITA Class II or Class III Fork Carriage
- ITA Class II or Class III Forks
- Critical Wiring Harness Connectors are Waterproof
- Contoured, Easy to Grip, Hydraulic Control Lever Knobs
- Overhead Guard Mounted Headlights

PNEUMATIC

- Stationary LP Tank Bracket
- "Komfort S" Full Suspension Seat - Vinyl with Orange Seat Belt
- **TIRES:**
 - Single Drive, Pneumatic
 - Steer, Pneumatic

CUSHION

- Fold Down LP Tank Bracket
- "Komfort S" Full Suspension Seat - Vinyl with Orange Seat Belt
- Komfort Seat & Operator Restraint System with Lap Belt (Standard only on FG20ST-16)
- **TIRES:**
 - Drive, Lug Cushion
 - Steer, Lug Cushion

OPTIONAL EQUIPMENT

- Warning Lights & Audible Travel Alarms
- Tilt Cylinder Boots
- Cotton-Core Radiator
- Spinner Knob Steering Wheel
- Dual-Fuel System (Pneumatic Only)
- Sideshifter - Integral or Hang-On
- 4-Way Valve and Internal Hosing
- Seats
- Tires
- Masts: 2-Stage, 3-Stage & 4-Stage
- Fire Extinguisher
- Attachments
- Rear Assist Grip with Horn Button
- Steel Cab (Pneumatic Only)

FORKS:

- 36 in. (915 mm)
- 42 in. (1,070 mm)
- 48 in. (1,220 mm)
- 54 in. (1,370 mm)
- 60 in. (1,520 mm)
- 72 in. (1,820 mm)

MODELS

BX50 Series

LPG/Dual Fuel Engine Forklift Availability

LPG = ●

Dual Fuel = ■

Capacity, lbs.	4,000	5,000	6,000	6,500
Cushion Tire	●	●	●	●
Pneumatic Tire	■	■	■	■



BX50 CUSHION SPECIFICATIONS

SPECIFICATIONS

Characteristics	1.2	Model		Manufacturer's Designation		FG20ST-16	FG25ST-16	FG25SHT-16	FG30SHT-16	FG32SHT-16	
	1.3	Power Type				LPG	LPG	LPG	LPG	LPG	
Weight	1.4	Operation Type				Sitting	Sitting	Sitting	Sitting	Sitting	
	1.5	Rated Capacity		Q	Rated Capacity	lb (kg)	4,000 (1,815)	5,000 (2,270)	5,000 (2,270)	6,000 (2,725)	6,500 (2,950)
	1.6	Load Center		c	Rated Load Center	in. (mm)	24 (600)	24 (600)	24 (600)	24 (600)	24 (600)
	1.8	Load Distance		x	Front Axle Center to Fork Face	in. (mm)	16.9 (430)	16.9 (430)	16.9 (430)	17.3 (440)	17.3 (440)
Tires	1.9	Wheelbase		y		in. (mm)	55.1 (1,400)	55.1 (1,400)	55.1 (1,400)	57.1 (1,450)	57.1 (1,450)
	2.1	Service Weight		2-stage std. mast & forks		lb (kg)	7,300 (3,310)	8,180 (3,710)	8,180 (3,710)	9,440 (4,280)	9,920 (4,500)
	2.2	Axle Loading	Loaded	Front	lb (kg)	9,820 (4,455)	11,330 (5,140)	11,330 (5,140)	13,260 (6,015)	14,000 (6,350)	
	2.2.1			Rear	lb (kg)	1,480 (670)	1,850 (840)	1,850 (840)	2,180 (990)	2,430 (1,100)	
	2.3		Unloaded	Front	lb (kg)	2,820 (1,280)	2,600 (1,180)	2,600 (1,180)	2,870 (1,300)	2,740 (1,245)	
2.3.1	Rear			lb (kg)	4,480 (2,030)	5,580 (2,530)	5,580 (2,530)	6,570 (2,980)	7,180 (3,255)		
Dimensions	3.1	Tire Type				Cushion	Cushion	Cushion	Cushion	Cushion	
	3.2	Tire Size		Front		21 - 7 - 15	21 - 7 - 15	21 - 7 - 15	21 - 8 - 15	21 - 8 - 15	
	3.3			Rear		16.25 - 5 - 11.25	16.25 - 5 - 11.25	16.25 - 5 - 11.25	16.25 - 6 - 11.25	16.25 - 6 - 11.25	
	3.5	Number of Wheel		Front/Rear (x=driven)		2x/2	2x/2	2x/2	2x/2	2x/2	
	3.6	Tread, Front		b10	in. (mm)	34.6 (879)	34.6 (879)	34.6 (879)	35.2 (895)	35.2 (895)	
	3.7	Tread, Rear		b11	in. (mm)	35.4 (900)	35.4 (900)	35.4 (900)	34.8 (885)	34.8 (885)	
	Performance	4.1	Tilting Angle - 2 stage masts		a / b	Forward/Backward	degree	6/8	6/8	6/8	6/8
4.1.1		Tilting Angle - 3 stage masts		a / b	Forward/Backward	degree	6/5	6/5	6/5	6/5	
4.2		Mast Height, Lowered		h1	2-stage Mast	in. (mm)	85.5 (2,170)	85.5 (2,170)	85.5 (2,170)	88.5 (2,250)	
4.3		Std. Free Lift Height		h2	2-stage Std. Mast, from Ground	in. (mm)	5.5 (140)	5.5 (140)	5.5 (140)	5.5 (140)	
4.5		Mast Height, Extended†		h4	2-stage Std. Mast	in. (mm)	176 (4,470)	176 (4,470)	176 (4,470)	176 (4,470)	
4.6		Max Fork Height**		h5	2-stage Std. Mast	in. (mm)	128 (3,250)	128 (3,250)	128 (3,250)	128 (3,250)	
4.7		Height, Overhead Guard		h6		in. (mm)	80.9 (2,055)	80.9 (2,055)	80.9 (2,055)	80.9 (2,055)	
4.19		Length, with Std. Forks		L1		in. (mm)	132.9 (3,375)	135.4 (3,440)	135.4 (3,440)	137.8 (3,500)	139.2 (3,535)
4.20		Length, to Fork Face		L2		in. (mm)	90.7 (2,305)	93.3 (2,370)	93.3 (2,370)	95.7 (2,430)	97 (2,465)
4.21		Width, at Tire		b1	Single	in. (mm)	42.1 (1,070)	42.1 (1,070)	42.1 (1,070)	43.3 (1,100)	43.3 (1,100)
4.22		Forks		s/e/l	Thickness x Width x Length	in. (mm)	1.6 x 4 x 42 (40 x 100 x 1,070)	1.6 x 4 x 42 (40 x 100 x 1,070)	1.6 x 4 x 42 (40 x 100 x 1,070)	2 x 5 x 42 (50 x 125 x 1,070)	2 x 6 x 42 (50 x 125 x 1,070)
4.24		Carriage Width / ITA Class		b3		in. (mm)	37 (940) / II	37 (940) / II	37 (940) / II	37 (940) / III	37 (940) / III
4.31		Ground Clearance		m1	Under Mast	in. (mm)	5.5 (140)	5.5 (140)	5.5 (140)	5.5 (140)	
4.32				m2	at Center of Wheelbase	in. (mm)	3.9 (100)	3.9 (100)	3.9 (100)	3.9 (100)	
4.33	Aisle Width ††		Ast	2-stage mast	in. (mm)	92.5 (2,350)	94.5 (2,400)	94.5 (2,400)	98.8 (2,510)	100 (2,540)	
4.35	Turning Radius		Wa	outside	in. (mm)	75.6 (1,920)	77.6 (1,970)	77.6 (1,970)	81.5 (2,070)	82.7 (2,100)	
Engine	5.1	Travel Speed (FWD)		Loaded	mph (km/h)	10.6 (17)	10.6 (17)	10.6 (17)	10.6 (17)	10.6 (17)	
		Unloaded	mph (km/h)	10.6 (17)	10.6 (17)	10.6 (17)	10.6 (17)	10.6 (17)	10.6 (17)		
	5.2	Lifting Speed		Loaded	fpm (mm/s)	120 (610)	120 (610)	120 (610)	104.3 (530)	104.3 (530)	
		Unloaded	fpm (mm/s)	124 (630)	124 (630)	124 (630)	124 (630)	108 (550)			
	5.3	Lowering Speed		Loaded	fpm (mm/s)	98 (500)	98 (500)	98 (500)	98 (500)	98 (500)	
		Unloaded	fpm (mm/s)	98 (500)	98 (500)	98 (500)	98 (500)	98 (500)			
	5.6	Max. Drawbar Pull		Loaded	lb (kN)	4,300 (19.3)	4,300 (19.3)	5,500 (24.5)	5,500 (24.5)	5,200 (23)	
	5.8	Max. Gradeability		Loaded 1.5 km/h, 3 min rating		%	36	30	39	31	28.5
5.10	Service Brake		Operation/Control			Foot/Hydraulic	Foot/Hydraulic	Foot/Hydraulic	Foot/Hydraulic	Foot/Hydraulic	
5.11	Parking Brake		Operation/Control			Hand/Mechanical	Hand/Mechanical	Hand/Mechanical	Hand/Mechanical	Hand/Mechanical	
Others	5.12	Steering		Type			FHPS	FHPS	FHPS	FHPS	
	7.1	Make					GCT	GCT	GCT	GCT	GCT
		Model					GK21	GK21	GK25	GK25	GK25
	7.2	Rated Output, SAE Gross				HP (kW)	54 (40)	54 (40)	60 (44)	60 (44)	60 (44)
	7.3	Rated RPM				min-1	2,700	2,700	2,700	2,700	2,700
7.3.1	Max. Torque, SAE net				lb-ft (Nm) @ rpm	111 (151) @ 2,000	111 (151) @ 2,000	136 (185) @ 2,000	136 (185) @ 2,000	136 (185) @ 2,000	
7.4	No. of Cylinder/Displacement				Cu. In. (cm3)	4/126 (2,065)	4/126 (2,065)	4/152 (2,488)	4/152 (2,488)	4/152 (2,488)	
8.2	Relief Pressure for Attachment				PSI (Bar)	2,630 (181)	2,630 (181)	2,630 (181)	2,630 (181)	2,630 (181)	
8.7	Transmission					Powershift	Powershift	Powershift	Powershift	Powershift	
8.8	Sound Level		At Operator Ears		dB	82	82	83	83	83	

NOTE: Most values shown in this publication are rounded. Therefore, direct conversion between metric and English or Imperial may be slightly different from those shown. The performance of machines is affected by the condition of the truck and how it is equipped, as well as the nature and condition of the operating area. If these specifications are critical or if your needs exceed the specifications shown here, discuss the proposed application with your authorized dealer.

*Optional masts, attachments, longer load dimensions, and higher lifting heights may result in downrating of the capacity. Contact your authorized dealer.

**Other mast heights available. See MAST DATA chart for other standard mast heights. Contact your authorized dealer.

†Includes 48-inch (1,220 mm) high load backrest. Contact your authorized dealer.

††Add load distance and clearance. Contact your authorized dealer.

BX50 SERIES

DIMENSIONS

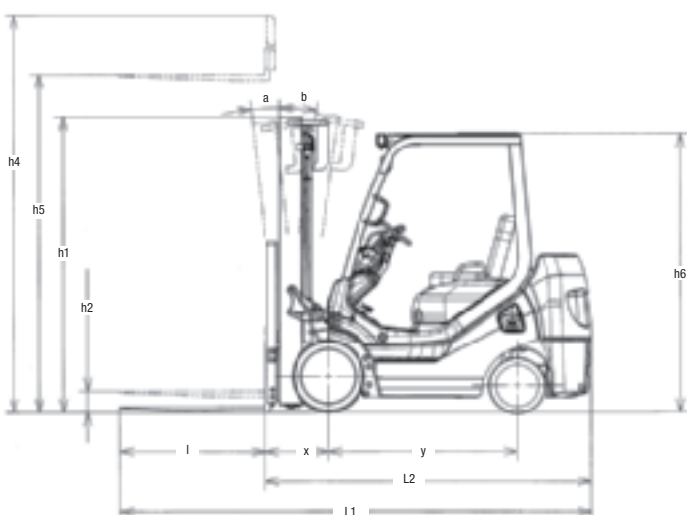
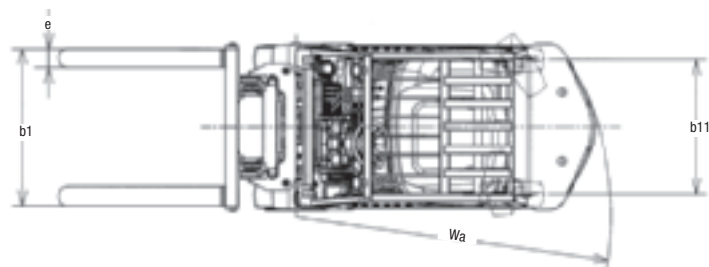

Dimensions of the FG25ST-16

SUMMARY OF BX50 FEATURES

- EPA compliant GK21 and GK25 industrial engines with high torque at low RPMs for power and fuel efficiency
- Komfort Zone™ dual floating structure uses drive train cushion mounts and suspension compartment mounts to isolate the operator from engine and floor vibration
- EZlift™ Hydraulic System with tandem pump provides fast and controllable lifting speed at low engine RPM
- A full floating transmission with high capacity oil cooler for the torque converter, aluminum alloy transmission case for better heat dissipation, and highly reliable, dust resistant, double sealed universal joint design increases performance and reliability
- Self-adjusting brakes with thicker drums improve heat resistance in severe duty applications
- Improved steer axle with integral double acting, double ended cylinder, high capacity kingpin needle bearings, and heavy-duty seals increases durability
- EZview® mast with improved visibility window, combined with low profile dash display, offers the operator an unrestricted view to the fork tips and surrounding area
- KOPS (Komatsu Operator Presence System) Plus locks out lift, lower, tilt and travel functions when the operator leaves the seat for longer than three seconds

MAST SPECIFICATIONS

Maximum Fork Height in. (mm)	Mast Height Lowered in. (mm)	Mast Height Extended in. (mm)	Free Lift in. (mm)
EZview® FG20ST/25ST/25SHT			
2-STAGE FREE VIEW (FV)			
82 (2,080)	62.5 (1,585)	130 (3,300)	5.5 (140)
106 (2,690)	74.5 (1,890)	154 (3,910)	5.5 (140)
114 (2,895)	78.5 (1,995)	162 (4,115)	5.5 (140)
128 (3,250)	85.5 (2,170)	176 (4,470)	5.5 (140)
130 (3,300)	86.5 (2,195)	178 (4,520)	5.5 (140)
146 (3,705)	94.5 (2,400)	194 (4,925)	5.5 (140)
158 (4,010)	100.5 (2,550)	206 (5,230)	5.5 (140)
2-STAGE FULL FREE VIEW (FFV)			
106 (2,690)	74.5 (1,890)	154 (3,910)	26.5 (670)
114 (2,895)	78.5 (1,995)	162 (4,115)	30.5 (775)
128 (3,250)	85.5 (2,170)	176 (4,470)	37.5 (950)
3-STAGE FULL FREE VIEW (TFV)			
152.5 (3,870)	73.5 (1,865)	200.5 (5,090)	25.5 (645)
167.5 (4,255)	78.5 (1,995)	215.5 (5,475)	30.5 (775)
188.5 (4,785)	85.5 (2,170)	236.5 (6,010)	37.5 (950)
198.5 (5,040)	89.5 (2,275)	246.5 (6,260)	41.5 (1,055)
216.5 (5,500)	97.5 (2,475)	264.5 (6,720)	49.5 (1,255)
235.5 (5,980)	106.5 (2,705)	283.5 (7,200)	58.5 (1,485)
EZview® FG30SHT			
2-STAGE FREE VIEW (FV)			
82 (2,080)	62.5 (1,585)	130 (3,300)	5.5 (140)
106 (2,690)	74.5 (1,890)	154 (3,910)	5.5 (140)
114 (2,895)	78.5 (1,995)	162 (4,115)	5.5 (140)
128 (3,250)	85.5 (2,170)	176 (4,470)	5.5 (140)
130 (3,300)	86.5 (2,195)	178 (4,520)	5.5 (140)
146 (3,705)	94.5 (2,400)	194 (4,925)	5.5 (140)
158 (4,010)	100.5 (2,550)	206 (5,230)	5.5 (140)
2-STAGE FULL FREE VIEW (FFV)			
106.5 (2,690)	75.5 (1,915)	154 (3,910)	26.5 (670)
114.5 (2,905)	79.5 (2,020)	162.5 (4,125)	31.5 (800)
128.5 (3,260)	86.5 (2,195)	176.5 (4,480)	38.5 (975)
3-STAGE FULL FREE VIEW (TFV)			
150.5 (3,820)	74.5 (1,890)	198.5 (5,040)	26.5 (670)
162.5 (4,125)	78.5 (1,995)	210.5 (5,345)	30.5 (775)
183.5 (4,660)	85.5 (2,170)	231.5 (5,880)	37.5 (950)
190.5 (4,835)	88.5 (2,245)	238.5 (6,055)	40.5 (1,025)
211.5 (5,370)	97.5 (2,475)	259.5 (6,590)	49.5 (1,255)
217.5 (5,525)	99.5 (2,530)	265.5 (6,745)	51.5 (1,310)
230.5 (5,855)	106.5 (2,705)	278.5 (7,070)	58.5 (1,485)
EZview® FG32SHT			
2-STAGE FREE VIEW (FV)			
82 (2,080)	65.5 (1,665)	130 (3,300)	5.5 (140)
106 (2,690)	77.5 (1,970)	154 (3,910)	5.5 (140)
114 (2,895)	81.5 (2,070)	162 (4,115)	5.5 (140)
128 (3,250)	88.5 (2,250)	176 (4,470)	5.5 (140)
130 (3,300)	89.5 (2,275)	178 (4,520)	5.5 (140)
146 (3,705)	97.5 (2,475)	194 (4,925)	5.5 (140)
158 (4,010)	103.5 (2,630)	206 (5,230)	5.5 (140)
3-STAGE FULL FREE VIEW (TFV)			
150.5 (3,820)	76.5 (1,945)	198.5 (5,040)	28.5 (725)
162.5 (4,125)	80.5 (2,045)	210.5 (5,345)	32.5 (825)
183.5 (4,660)	87.5 (2,220)	231.5 (5,880)	39.5 (1,005)
189.5 (4,810)	91.5 (2,325)	237.5 (6,030)	43.5 (1,105)
210.5 (5,345)	100.5 (2,550)	258.5 (6,565)	52.5 (1,335)
217.5 (5,525)	103.5 (2,630)	265.5 (6,740)	55.5 (1,410)
230.5 (5,855)	110.5 (2,805)	278.5 (7,070)	62.5 (1,585)

NOTE: Specifications for 4-Stage Full Free View (QFV) Masts are not indicated. Please consult your authorized dealer for information and availability.

BX50 PNEUMATIC SPECIFICATIONS

SPECIFICATIONS

	Model	Manufacturer's Designation		FG20T-16		FG25T-16		FG25HT-16		FG30HT-16		FG32HT-16		
				LPG / Dual Fuel		LPG / Dual Fuel		LPG / Dual Fuel		LPG / Dual Fuel		LPG / Dual Fuel		
Characteristics	1.2	Manufacturer's Designation												
	1.3	Power Type												
	1.4	Operation Type				Sitting		Sitting		Sitting		Sitting		
	1.5	Rated Capacity	Q	Rated Capacity	lb (kg)	4,000 (1,815)	5,000 (2,270)	5,000 (2,270)	6,000 (2,725)	6,500 (2,950)				
	1.6	Load Center	c	Rated Load Center	in. (mm)	24 (600)	24 (600)	24 (600)	24 (600)	24 (600)				
	1.8	Load Distance	x	Front Axle Center to Fork Face	in. (mm)	17.9 (455)	17.9 (455)	17.9 (455)	19.1 (485)	19.1 (485)				
1.9	Wheelbase	y		in. (mm)	65 (1,650)	65 (1,650)	65 (1,650)	66.9 (1,700)	66.9 (1,700)					
Weight	2.1	Service Weight	2-stage std. mast & forks		lb (kg)	7,180 (3,255)	7,950 (3,605)	7,950 (3,605)	9,410 (4,270)	9,800 (4,445)				
	2.2	Axle Loading	Loaded	Front	lb (kg)	9,880 (4,480)	11,360 (5,155)	11,360 (5,155)	13,510 (6,130)	14,200 (6,440)				
	2.2.1			Rear	lb (kg)	1,300 (590)	1,590 (720)	1,590 (720)	1,910 (865)	2,110 (955)				
	2.3		Unloaded	Front	lb (kg)	3,270 (1,485)	3,110 (1,410)	3,110 (1,410)	3,600 (1,635)	3,480 (1,580)				
	2.3.1			Rear	lb (kg)	3,900 (1,770)	4,840 (2,195)	4,840 (2,195)	5,810 (2,635)	6,320 (2,865)				
Tires	3.1	Tire Type			Pneumatic		Pneumatic		Pneumatic		Pneumatic		Pneumatic	
	3.2	Tire Size	Front		7 - 12 - 12PR		7 - 12 - 12PR		7 - 12 - 12PR		18 x 9 - 15 - 12PR (I)		18 x 9 - 15 - 12PR (I)	
	3.3		Rear		6 - 9 - 10PR		6 - 9 - 10PR		6 - 9 - 10PR		8.15 - 15 - 12PR		8.15 - 15 - 12PR	
	3.5	Number of Wheel	Front/Rear (x=driven)		2x/2		2x/2		2x/2		2x/2		2x/2	
	3.6	Tread, Front	b10		in. (mm)	38 (965)	38 (965)	38 (965)	40.4 (1,025)	40.4 (1,025)				
3.7	Tread, Rear	b11		in. (mm)	37.8 (960)	37.8 (960)	37.8 (960)	38 (965)	38 (965)					
Dimensions	4.1	Tilting Angle - 2 stage masts	a / b	Forward/Backward	degree	6/12	6/12	6/12	6/12	6/12				
	4.1.1	Tilting Angle - 3 stage masts	a / b	Forward/Backward	degree	6/5	6/5	6/5	6/5	6/5				
	4.2	Mast Height, Lowered	h1	2-stage Mast	in. (mm)	85.5 (2,170)	85.5 (2,170)	85.5 (2,170)	85.5 (2,160)	88.5 (2,250)				
	4.3	Std. Free Lift Height	h2	2-stage Std. Mast, from Ground	in. (mm)	5.5 (140)	5.5 (140)	5.5 (140)	5.5 (140)	5.5 (140)				
	4.5	Mast Height, Extended†	h4	2-stage Std. Mast	in. (mm)	176 (4,470)	176 (4,470)	176 (4,470)	176 (4,470)	176 (4,470)				
	4.6	Max Fork Height**	h5	2-stage Std. Mast	in. (mm)	128 (3,250)	128 (3,250)	128 (3,250)	128 (3,250)	128 (3,250)				
	4.7	Height, Overhead Guard	h6		in. (mm)	83.1 (2,110)	83.1 (2,110)	83.1 (2,110)	83.9 (2,130)	83.9 (2,130)				
	4.19	Length, with Std. Forks	L1		in. (mm)	141.5 (3,595)	144.5 (3,670)	144.5 (3,670)	148.8 (3,780)	150.6 (3,825)				
	4.20	Length, to Fork Face	L2		in. (mm)	99.4 (2,525)	102.4 (2,600)	102.4 (2,600)	106.7 (2,710)	108.5 (2,755)				
	4.21	Width, at Tire	b1	Single	in. (mm)	45.3 (1,150)	45.3 (1,150)	45.3 (1,150)	48.6 (1,235)	48.6 (1,235)				
	4.22	Forks	s/e/l	Thickness x Width x Length	in. (mm)	1.6 x 4 x 42 (40 x 100 x 1,070)	1.6 x 4 x 42 (40 x 100 x 1,070)	1.6 x 4 x 42 (40 x 100 x 1,070)	2 x 5 x 42 (50 x 125 x 1,070)	2 x 5 x 42 (50 x 125 x 1,070)				
	4.24	Carriage Width / ITA Class	b3		in. (mm)	41 (1,040) / II	41 (1,040) / II	41 (1,040) / II	41 (1,041) / III	41 (1,041) / III				
	4.31	Ground Clearance	m1	Under Mast	in. (mm)	5.5 (140)	5.5 (140)	5.5 (140)	5.5 (140)	5.5 (140)				
	4.32		m2	at Center of Wheelbase	in. (mm)	6.3 (160)	6.3 (160)	6.3 (160)	7.5 (190)	7.5 (190)				
4.33	Aisle Width ††	Ast	2-stage mast	in. (mm)	104.1 (2,645)	106.1 (2,695)	106.1 (2,695)	112.4 (2,855)	114.4 (2,905)					
4.35	Turning Radius	Wa	outside	in. (mm)	86.2 (2,190)	88.2 (2,240)	88.2 (2,240)	93.3 (2,370)	95.3 (2,420)					
Performance	5.1	Travel Speed (FWD)	Loaded	mph (km/h)	11.2 (18)	11.2 (18)	11.2 (18)	11.5 (18.5)	10.9 (17.5)					
			Unloaded	mph (km/h)	11.8 (19)	11.8 (19)	11.8 (19)	12.1 (19.5)	11.5 (18.5)					
	5.2	Lifting Speed	Loaded	fpm (mm/s)	120 (610)	120 (610)	120 (610)	104 (530)	104 (530)					
			Unloaded	fpm (mm/s)	124 (630)	124 (630)	124 (630)	124 (630)	124 (630)					
	5.3	Lowering Speed	Loaded	fpm (mm/s)	98 (500)	98 (500)	98 (500)	98 (500)	98 (500)					
			Unloaded	fpm (mm/s)	98 (500)	98 (500)	98 (500)	98 (500)	98 (500)					
	5.6	Max. Drawbar Pull	Loaded	lb (kN)	4,000 (17.6)	4,000 (17.6)	4,700 (21)	4,600 (20.6)	4,600 (20.6)					
	5.8	Max. Gradeability	Loaded 1.5 km/h, 3 min rating		%	32	27	34	27	25				
5.10	Service Brake	Operation/Control			Foot/Hydraulic	Foot/Hydraulic	Foot/Hydraulic	Foot/Hydraulic	Foot/Hydraulic					
5.11	Parking Brake	Operation/Control			Hand/Mechanical	Hand/Mechanical	Hand/Mechanical	Hand/Mechanical	Hand/Mechanical					
5.12	Steering	Type			FHPS	FHPS	FHPS	FHPS	FHPS					
Engine	7.1	Make			GCT		GCT		GCT		GCT		GCT	
		Model			GK21		GK21		GK25		GK25		GK25	
	7.2	Rated Output, SAE Gross			HP (kW)	54 (40)	54 (40)	60 (44)	60 (44)	60 (44)				
	7.3	Rated RPM			min-1	2,700	2,700	2,700	2,700	2,700				
	7.3.1	Max. Torque, SAE net			lb-ft (Nm) @ rpm	111 (151) @ 2,000	111 (151) @ 2,000	136 (152) @ 2,000	136 (152) @ 2,000	136 (152) @ 2,000				
	7.4	No. of Cylinder/Displacement			Cu. In. (cm3)	4/126 (2,065)	4/126 (2,065)	4/152 (2,488)	4/152 (2,488)	4/152 (2,488)				
7.6	Fuel Tank Capacity			US Gallons (L)	15.3 (58)	15.3 (58)	15.3 (58)	15.3 (58)	15.3 (58)					
Others	8.2	Relief Pressure for Attachment			PSI (Bar)	2,630 (181)	2,630 (181)	2,630 (181)	2,630 (181)	2,630 (181)				
	8.7	Transmission				Powershift	Powershift	Powershift	Powershift	Powershift				
8.8	Sound Level	At Operator Ears		dB	82	82	83	83	83					

NOTE: Most values shown in this publication are rounded. Therefore, direct conversion between metric and English or Imperial may be slightly different from those shown. The performance of machines is affected by the condition of the truck and how it is equipped, as well as the nature and condition of the operating area. If these specifications are critical or if your needs exceed the specifications shown here, discuss the proposed application with your authorized dealer.

*Optional masts, attachments, longer load dimensions, and higher lifting heights may result in downrating of the capacity. Contact your authorized dealer.

**Other mast heights available. See MAST DATA chart for other standard mast heights. Contact your authorized dealer.

†Includes 48-inch (1,220 mm) high load backrest. Contact your authorized dealer.

††Add load distance and clearance. Contact your authorized dealer.

DIMENSIONS

MAST SPECIFICATIONS

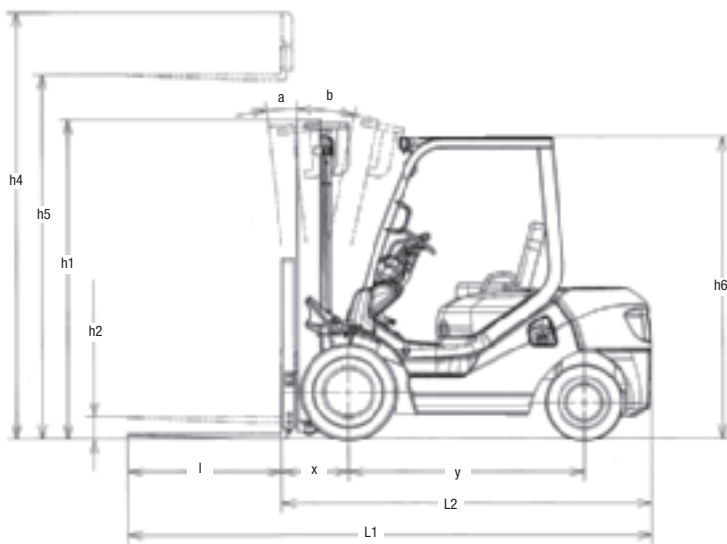
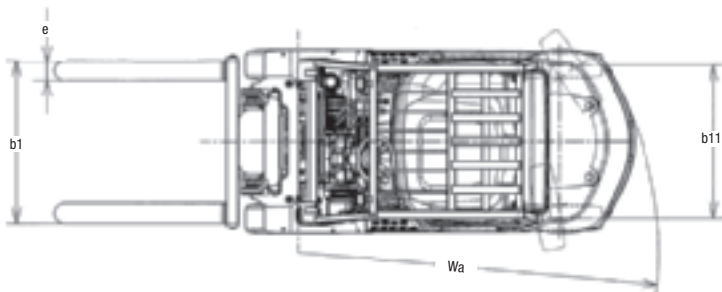

Dimensions of the FG25T-16

SUMMARY OF BX50 FEATURES

- EPA compliant GK21 and GK25 industrial engines with high torque at low RPMs for power and fuel efficiency
- Komfort Zone™ dual floating structure uses drive train cushion mounts and suspension compartment mounts to isolate the operator from engine and floor vibration
- EZlift™ Hydraulic System with tandem pump provides fast and controllable lifting speed at low engine RPM
- A full floating transmission with high capacity oil cooler for the torque converter, aluminum alloy transmission case for better heat dissipation, and highly reliable, dust resistant, double sealed universal joint design increases performance and reliability
- Self-adjusting brakes with thicker drums improve heat resistance in severe duty applications
- Improved steer axle with integral double acting, double ended cylinder, high capacity kingpin needle bearings, and heavy-duty seals increases durability
- EZview® mast with improved visibility window, combined with low profile dash display, offers the operator an unrestricted view to the fork tips and surrounding area
- KOPS (Komatsu Operator Presence System) Plus locks out lift, lower, tilt and travel functions when the operator leaves the seat for longer than three seconds

Maximum Fork Height in. (mm)	Mast Height Lowered in. (mm)	Mast Height Extended in. (mm)	Free Lift in. (mm)
EZview® FG20T/25T/25HT			
2-STAGE FREE VIEW (FV)			
106 (2,690)	74.5 (1,890)	154 (3,910)	5.5 (140)
116 (2,945)	79.5 (2,020)	164 (4,165)	5.5 (140)
128 (3,250)	85.5 (2,170)	176 (4,470)	5.5 (140)
146 (3,705)	94.5 (2,400)	194 (4,925)	5.5 (140)
158 (4,010)	100.5 (2,550)	206 (5,230)	5.5 (140)
170 (4,320)	106.5 (2,705)	218 (5,535)	5.5 (140)
2-STAGE FULL FREE VIEW (FFV)			
106 (2,690)	74.5 (1,890)	154 (3,910)	26.5 (670)
116 (2,945)	79.5 (2,020)	164 (4,165)	31.5 (800)
128 (3,250)	85.5 (2,170)	176 (4,470)	37.5 (950)
3-STAGE FULL FREE VIEW (TFV)			
152.5 (3,870)	73.5 (1,865)	200.5 (5,090)	25.5 (645)
170.5 (4,330)	79.5 (2,020)	218.5 (5,550)	31.5 (800)
188.5 (4,785)	85.5 (2,170)	236.5 (6,010)	37.5 (950)
198.5 (5,040)	89.5 (2,275)	246.5 (6,260)	41.5 (1,055)
216.5 (5,500)	97.5 (2,475)	264.5 (6,720)	49.5 (1,255)
235.5 (5,980)	106.5 (2,705)	283.5 (7,200)	58.5 (1,485)
EZview® FG30HT			
2-STAGE FREE VIEW (FV)			
106 (2,690)	74.5 (1,890)	154 (3,910)	5.5 (140)
116 (2,945)	80.5 (2,045)	164 (4,165)	5.5 (140)
128 (3,250)	85.5 (2,170)	176 (4,470)	5.5 (140)
146 (3,705)	94.5 (2,400)	194 (4,925)	5.5 (140)
158 (4,010)	100.5 (2,550)	206 (5,230)	5.5 (140)
170 (4,320)	106.5 (2,705)	218 (5,535)	5.5 (140)
2-STAGE FULL FREE VIEW (FFV)			
106.5 (2,690)	75.5 (1,915)	154.5 (3,925)	26.5 (670)
116.5 (2,905)	80.5 (2,045)	164.5 (4,165)	32.5 (825)
128.5 (3,260)	86.5 (2,195)	176.5 (4,480)	38.5 (975)
154.5 (3,925)	99.5 (2,530)	202.5 (5,145)	51.5 (1,310)
3-STAGE FULL FREE VIEW (TFV)			
150.5 (3,820)	74.5 (1,890)	198.5 (5,040)	26.5 (670)
168.5 (4,280)	80.5 (2,045)	216.5 (5,500)	32.5 (825)
183.5 (4,660)	85.5 (2,170)	231.5 (5,880)	37.5 (950)
190.5 (4,835)	88.5 (2,245)	238.5 (6,055)	40.5 (1,025)
211.5 (5,370)	97.5 (2,475)	259.5 (6,590)	49.5 (1,255)
230.5 (5,855)	106.5 (2,705)	278.5 (7,070)	58.5 (1,485)
237.5 (6,030)	109.5 (2,780)	285.5 (7,250)	61.5 (1,560)
242.5 (6,160)	117.5 (2,985)	290.5 (7,380)	64.5 (1,640)
EZview® FG32HT			
2-STAGE FREE VIEW (FV)			
106 (2,690)	77.5 (1,970)	154 (3,910)	5.5 (140)
116 (2,945)	81.5 (2,070)	164 (4,165)	5.5 (140)
128 (3,250)	88.5 (2,250)	176 (4,470)	5.5 (140)
146 (3,705)	97.5 (2,475)	194 (4,925)	5.5 (140)
158 (4,010)	103.5 (2,630)	206 (5,230)	5.5 (140)
170 (4,320)	109.5 (2,780)	218 (5,535)	5.5 (140)
3-STAGE FULL FREE VIEW (TFV)			
150.5 (3,820)	76.5 (1,945)	198.5 (5,040)	28.5 (725)
162.5 (4,125)	80.5 (2,045)	210.5 (5,345)	32.5 (825)
168.5 (4,280)	82.5 (2,095)	216.5 (5,500)	34.5 (875)
183.5 (4,660)	87.5 (2,220)	231.5 (5,880)	39.5 (1,005)
189.5 (4,810)	91.5 (2,325)	237.5 (6,030)	43.5 (1,105)
217.5 (5,525)	103.5 (2,630)	265.5 (6,740)	55.5 (1,410)
230.5 (5,855)	110.5 (2,805)	278.5 (7,070)	62.5 (1,585)
238.5 (6,055)	114.5 (2,910)	286.5 (7,275)	66.5 (1,690)

NOTE: Specifications for 4-Stage Full Free View (QFV) Masts are not indicated. Please consult your authorized dealer for information and availability.

We're Close By

Komatsu Forklift U.S.A. has a dealer network covering all regions of the United States and Canada. So, it doesn't matter where you are located, a Komatsu Forklift U.S.A. dealer will be there ready to provide the quality service and solutions you need.

BX50 SERIES



KOM101-00

©2018 Komatsu America Corp.

Printed in USA

K3(5)OTP

3/18 (EV-1)

KOMATSU®

Note: All comparisons and claims of improved performance made herein are made with respect to the prior Komatsu model unless otherwise specifically stated.

www.KomatsuAmerica.com

www.KomatsuForkliftUSA.com

Komatsu America Corp. is an authorized licensee of Komatsu Ltd. Materials and specifications are subject to change without notice. Photos may include optional equipment.

KOMATSU® is a registered trademark of Komatsu Ltd.

All other trademarks and service marks used herein are the property of Komatsu Ltd., Komatsu America Corp. or their respective owners or licensees.