

WSRX30



CLARK WSRX30 A Power Steering Walkie Reach Truck

FEATURES & BENEFITS

- **HYDRAULICS**

Lift cylinder has hard chrome plated rods. Pump unit including motor, solenoid, gear pump, and pressure compensated lowering valve are mounted high in the power compartment for ease of service.

- **ELECTRICAL**

24-Volt ZAPI Combi-ACx, travel control with matching drive motor provide high performance throughout the entire speed range. Travel speed remains constant relative to throttle position regardless of load. Separately fused power control circuits, quick disconnect EPD power cut off, and hour meter /battery discharge indicator combination gauge complete the system. Power configurations and diagnostic features are displayed with a ZAPI handheld console.

- **BRAKES**

Regenerative electromagnetic brake is mounted on the motor armature shaft multiplying the braking power through the transmission. Brake is applied when the control arm is in the vertical or horizontal handle position. Travel speed is reduced when forks are above 12" fork height. Neutral braking resists roll back on ramps.

- **CONTROLS**

Travel, lift, and lower functions are located in the ergonomic operator handle. All operator controls are accessible without having to lift the hand from the handle.

Angle grips are designed to allow easy operation with either hand. Wrap around guard, reversing switch, thumb control, and horn are standard.

Top mounted tiller arm offers excellent operator comfort and minimum steering effort. Gas assisted spring gently returns handle to vertical position.

- **TRANSMISSION**

Vertically mounted drive motor is direct mounted to gear housing. Oil bathed ZF GK10 hypoid bevel gear drive train with tapered roller bearings transfers power to axle. State of the art optimized gear technology supplies advantages such as minimal envelope circle, zero maintenance, low noise level, high efficiency and high performance.

- **MAST & PANTOGRAPH**

I-beam mast with dual lifting chains. Pantograph stroke extends the fork carriage beyond the units straddle legs, with integral tilt and sideshift.

- **STRADDLE LEGS & FORKS**

Fixed straddle leg inside dimensions (ID) available at 34" or 42" resulting in a 42" or 50" outside dimension (OD).

Class 2 ITA fork carriage with 36" tall load back rest and 42" Forks spacing is adjustable.



SPECIFICATIONS

- CAPACITY**
 3000 lbs. at 24" Load Center
- BATTERY COMPARTMENTS**
 31.6" x 9.06" x open
 31.6" x 13.1" x open (189" MFH)
- SPEED**
 ZAPI travel controller
TRAVEL
 Variable from 0 mph to 3.41 mph empty
 Variable from 0 mph to 3.1 mph loaded
- LIFT**
 Up to 40 fpm empty.
 Up to 35 fpm loaded—3000lbs
- LOWERING**
 Up to 29 fpm empty.
 Up to 57 fpm loaded—3000lbs
- WEIGHT**
 3,690-4,200lbs Chassis Only
- TIRES / WHEELS**
DRIVE
 10" x 4" polyurethane
DUAL LOAD
 (2) 4" x 2.75" polyurethane

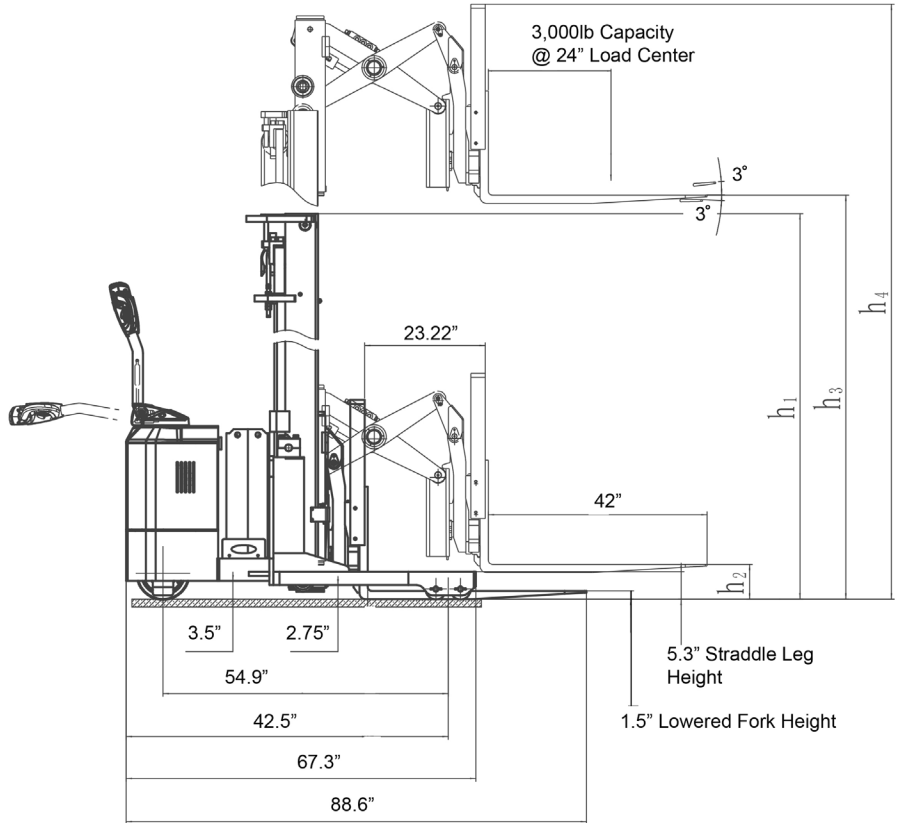

Overall length increased by up to 3" when control handle is perpendicular to the direction of travel

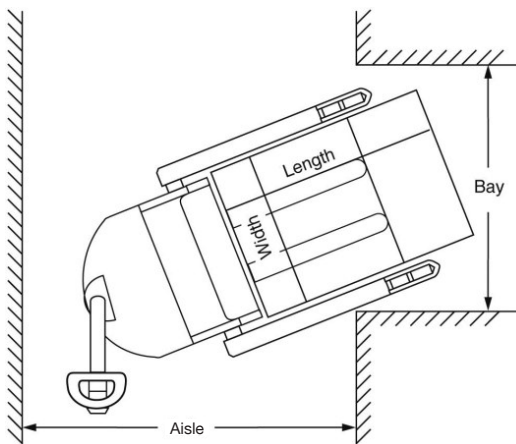
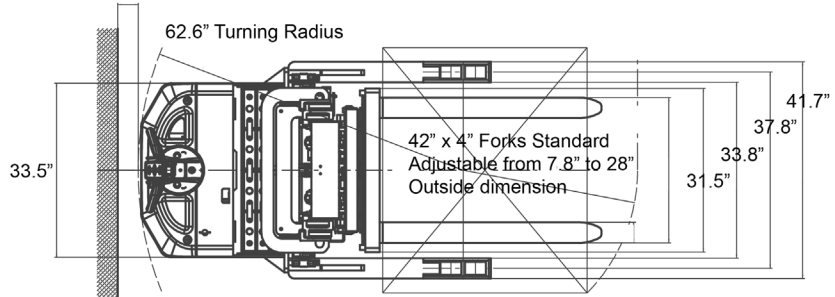

Aisle dimensions listed above assume the minimum bay width to be straddle OD plus 5" (2.5" on each either side of straddle leg). Straddle OD is the load width plus 8". Truck performance may vary due to application requirements' and changes in model design.

Model	Straddle ID/OD	Mast	Lift height (H3)	Col Height (H1)	Free Lift (H2)	Ext Height (H4)	Weight Complete
WSRX30	34/42 or 42/50	Two Stage	106"	73.5"	6.5"	144.25"	3690 lbs
WSRX30	34/42 or 42/50	Two Stage	126"	83"	6.5"	166.75"	3750 lbs
WSRX30	34/42 or 42/50	Three Stage	157"	77.5"	39.25"	195.25"	3980 lbs
WSRX30	42/50	Three Stage	189"	95.0"	39.25"	227.00"	4200 lbs

Aisle Guide

WSRX30 Right Angle Stacking

Load Length			
Load Width	36"	40"	48"
36"	79.5"	79.5"	79.5"
40"	81.0"	81.0"	81.0"
48"	85.3"	85.3"	85.3"

For ease of use add 8" to aisle dimension listed



CLARK Material Handling Company
 North American Headquarters
 700 Enterprise Drive • Lexington, KY 40510
 866-252-5275 • www.clarkmhc.com



59-894-0966